

Offers 2025

INDUSTRIAL
SUPPLIES LTD



Tooling solutions for the metalworking industry

All year
promotion





Complete Tooling Solutions

Contents

MFH High feed cutter	4
MFH Mini high feed cutter	7
MFH Boost high feed cutter	9
MA90	12
MEV	16
MEC	18
MEW	24
MEAS Aluminum Machining	28
MFWN	30
MFPN45	31
MB45	32
MRX	34
MRW	36
Vickers hardness conversion chart	37
MagicDrill DRV	38
MagicDrill DRA	40
KPK Part-off System	52
KGD groove and turning	54
Dynamic Boring Bar	56
Turning Kit Offers	58
Re-New, Much more than Regrinding	60
Kyocera Unimerco production facilities	64



MFH High feed cutter

HIGH EFFICIENCY MILLING CUTTER FOR VARIOUS APPLICATIONS



SOMT 10 insert type

Cutter Description	Cutting Diameter	Insert Description	Special Cutter Body price	Number of inserts required for Special promotion
MFH050R-10-4T-M	50	SOMT100420ER-GM	£50.00	50
MFH050R-10-5T-M	50	SOMT100420ER-GM	£50.00	50
MFH052R-10-4T-M	52	SOMT100420ER-GM	£52.00	50
MFH052R-10-5T-M	52	SOMT100420ER-GM	£52.00	50
MFH063R-10-5T-22M	63	SOMT100420ER-GM	£63.00	50
MFH063R-10-6T-22M	63	SOMT100420ER-GM	£63.00	50
MFH063R-10-5T-27M	63	SOMT100420ER-GM	£63.00	50
MFH063R-10-6T-27M	62	SOMT100420ER-GM	£63.00	50
MFH080R-10-7T-M	80	SOMT100420ER-GM	£80.00	50

SOMT 14 insert type

Cutter Description	Cutting Diameter	Insert Description	Special Cutter Body price	Number of inserts required for Special promotion
MFH063R-14-4T-22M	63	SOMT140520ER-GM	£63.00	50
MFH063R-14-5T-22M	63	SOMT140520ER-GM	£63.00	50
MFH063R-14-4T-27M	63	SOMT140520ER-GM	£63.00	50
MFH063R-14-5T-27M	63	SOMT140520ER-GM	£63.00	50
MFH066R-14-4T-22M	66	SOMT140520ER-GM	£66.00	50
MFH066R-14-5T-22M	66	SOMT140520ER-GM	£66.00	50
MFH066R-14-4T-27M	66	SOMT140520ER-GM	£66.00	50
MFH066R-14-5T-27M	66	SOMT140520ER-GM	£66.00	50
MFH080R-14-5T-M	80	SOMT140520ER-GM	£80.00	50
MFH080R-14-6T-M	80	SOMT140520ER-GM	£80.00	50
MFH100R-14-6T-M	100	SOMT140520ER-GM	£100.00	70
MFH100R-14-7T-M	100	SOMT140520ER-GM	£100.00	70
MFH125R-14-7T-M	125	SOMT140520ER-GM	£125.00	70
MFH160R-14-8T-M	160	SOMT140520ER-GM	£160.00	70

P	Steel	★
	Die steel	★
M	Austenitic stainless steel	★ ☆
	Martensitic stainless steel	☆
	Precipitation hardened stainless steel	★
K	Gray cast iron	★
	Nodular cast iron	★
N	Non-ferrous material	
S	Heat-resistant alloy	★
	Titanium alloy	★
H	Hardened material	☆

Insert grades



PR1835 PR1825 PR1810

Shape	Description
-------	-------------

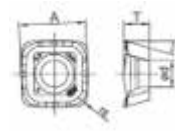

SOMT100420ER-GM PR1825
or
SOMT140520ER-GM PR1825

Choose the insert grade to suit the material being machined!

ORDERING EXAMPLE

50 mm Dia Cutter
MFH050R-10-4T-M

+

Inserts
SOMT100420ER-GM PR1825

Purchasing price = £50 + 50 inserts

MFH High feed cutter

HIGH EFFICIENCY MILLING CUTTER FOR VARIOUS APPLICATIONS



SOMT 10 insert type

	Cutter Description	Cutting Diameter	Insert Description	Special Cutter Body price	Number of inserts required for Special promotion
Straight Shank	MFH25-S25-10-2T	25	SOMT100420ER-GM	£25.00	30
	MFH28-S25-10-2T	28	SOMT100420ER-GM	£28.00	30
	MFH32-S32-10-2T	32	SOMT100420ER-GM	£32.00	30
	MFH32-S32-10-3T	32	SOMT100420ER-GM	£32.00	30
	MFH35-S32-10-2T	35	SOMT100420ER-GM	£35.00	30
	MFH35-S32-10-3T	35	SOMT100420ER-GM	£35.00	30
	MFH40-S32-10-3T	40	SOMT100420ER-GM	£40.00	40
	MFH40-S32-10-4T	40	SOMT100420ER-GM	£40.00	40
Weldon	MFH25-W25-10-2T	25	SOMT100420ER-GM	£25.00	30
	MFH32-W32-10-3T	32	SOMT100420ER-GM	£32.00	40
	MFH40-W32-10-3T	40	SOMT100420ER-GM	£40.00	40
	MFH40-W32-10-4T	40	SOMT100420ER-GM	£40.00	40
Long shank	MFH25-S25-10-2T-200	25	SOMT100420ER-GM	£25.00	40
	MFH28-S25-10-2T-200	28	SOMT100420ER-GM	£28.00	40
	MFH32-S32-10-2T-200	32	SOMT100420ER-GM	£32.00	40
	MFH35-S32-10-2T-200	35	SOMT100420ER-GM	£35.00	40
	MFH40-S32-10-4T-250	40	SOMT100420ER-GM	£40.00	40
Extra long shank	MFH25-S25-10-2T-300	25	SOMT100420ER-GM	£25.00	40
	MFH28-S25-10-2T-300	28	SOMT100420ER-GM	£28.00	40
	MFH32-S32-10-2T-300	32	SOMT100420ER-GM	£32.00	40
	MFH35-S32-10-2T-300	35	SOMT100420ER-GM	£35.00	40
	MFH40-S32-10-4T-300	40	SOMT100420ER-GM	£40.00	50



Shape	Description
	SOMT100420ER-GM PR1825

Choose the insert grade to suit the material being machined!

P	Steel	★
	Die steel	★
M	Austenitic stainless steel	★ ☆
	Martensitic stainless steel	☆
	Precipitation hardened stainless steel	★
K	Gray cast iron	★
	Nodular cast iron	★
N	Non-ferrous material	
S	Heat-resistant alloy	★
	Titanium alloy	★
H	Hardened material	☆

Insert grades



PR1835 PR1825 PR1810

ORDERING EXAMPLE

25 mm Dia Cutter
MFH25-S25-10-2T

+
Inserts
SOMT100420ER-GM PR1825

Purchasing price
= £25 + 30 inserts

MFH High feed cutter

HIGH EFFICIENCY MILLING CUTTER FOR VARIOUS APPLICATIONS



SOMT 10 insert type

Cutter Description	Cutting Diameter	Insert Description	Special Cutter Body price	Number of inserts required for Special promotion
MFH25-M12-10-2T	25	SOMT100420ER-GM	£25.00	40
MFH28-M12-10-2T	28	SOMT100420ER-GM	£28.00	40
MFH32-M16-10-2T	32	SOMT100420ER-GM	£32.00	40
MFH32-M16-10-3T	32	SOMT100420ER-GM	£32.00	40
MFH35-M16-10-2T	35	SOMT100420ER-GM	£35.00	40
MFH35-M16-10-3T	35	SOMT100420ER-GM	£35.00	40
MFH40-M16-10-3T	40	SOMT100420ER-GM	£40.00	40
MFH40-M16-10-4T	40	SOMT100420ER-GM	£40.00	40



Shape	Description
	SOMT100420ER-GM PR1825

Choose the insert grade to suit the material being machined!

P	Steel	★
	Die steel	★
M	Austenitic stainless steel	★ ☆
	Martensitic stainless steel	☆
	Precipitation hardened stainless steel	★
K	Gray cast iron	★
	Nodular cast iron	★
N	Non-ferrous material	
S	Heat-resistant alloy	★
	Titanium alloy	★
H	Hardened material	☆

Insert grades



PR1835 PR1825 PR1810

ORDERING EXAMPLE

25 mm Dia Cutter
MFH25-M12-10-2T

+
Inserts

SOMT100420ER-GM PR1825

Purchasing price
= £25 + 40 inserts

MFH **Mini** high feed cutter

HIGH EFFICIENCY MILLING CUTTER FOR VARIOUS APPLICATIONS



LOGU 03 insert type

	Cutter Description	Cutting Diameter	Insert Description	Special Cutter Body price	Number of inserts required for Special promotion
Standard Shank	MFH16-S16-03-2T	16	LOGU030310ER-GM	£16.00	40
	MFH20-S20-03-3T	20	LOGU030310ER-GM	£20.00	40
	MFH20-S20-03-4T	20	LOGU030310ER-GM	£20.00	40
	MFH25-S25-03-4T	25	LOGU030310ER-GM	£25.00	40
	MFH25-S25-03-5T	25	LOGU030310ER-GM	£25.00	40
	MFH32-S32-03-5T	32	LOGU030310ER-GM	£32.00	40
Over sized Shank	MFH17-S16-03-2T	17	LOGU030310ER-GM	£17.00	40
	MFH18-S16-03-2T	18	LOGU030310ER-GM	£18.00	40
	MFH22-S20-03-3T	22	LOGU030310ER-GM	£22.00	40
	MFH22-S20-03-4T	22	LOGU030310ER-GM	£22.00	40
	MFH28-S25-03-4T	28	LOGU030310ER-GM	£28.00	40
	MFH28-S25-03-5T	28	LOGU030310ER-GM	£28.00	40
Weldon	MFH16-W16-03-2T	16	LOGU030310ER-GM	£16.00	40
	MFH20-W20-03-3T	20	LOGU030310ER-GM	£20.00	40
	MFH20-W20-03-4T	20	LOGU030310ER-GM	£20.00	40
	MFH25-W25-03-4T	25	LOGU030310ER-GM	£25.00	40
	MFH25-W25-03-5T	25	LOGU030310ER-GM	£25.00	40
	MFH32-W32-03-6T	32	LOGU030310ER-GM	£32.00	40
Long Shank	MFH16-S16-03-2T-150	16	LOGU030310ER-GM	£16.00	40
	MFH20-S20-03-3T-160	20	LOGU030310ER-GM	£20.00	40
	MFH25-S25-03-4T-180	25	LOGU030310ER-GM	£25.00	40
	MFH32-S32-03-5T-200	32	LOGU030310ER-GM	£32.00	40

P	Steel	★
	Die steel	★
M	Austenitic stainless steel	★ ☆
	Martensitic stainless steel	☆
	Precipitation hardened stainless steel	★
K	Gray cast iron	★
	Nodular cast iron	★
N	Non-ferrous material	
S	Heat-resistant alloy	★
	Titanium alloy	★
H	Hardened material	☆

Insert grades



PR1835 PR1825 PR1810

Shape	Description
	LOGU030310ER-GM PR1825

Choose the insert grade to suit the material being machined!

ORDERING EXAMPLE	
16 mm Dia Cutter MFH16-S16-03-2T	+ Inserts LOGU030310ER-GM PR1825
Purchasing price = £16 + 40 inserts	



MFH **Mini** high feed cutter

HIGH EFFICIENCY MILLING CUTTER FOR VARIOUS APPLICATIONS

LOGU 03 insert type

Cutter Description	Cutting Diameter	Insert Description	Special Cutter Body price	Number of inserts required for Special promotion
MFH16-M08-03-2T	16	LOGU030310ER-GM	£16.00	40
MFH17-M08-03-2T	17	LOGU030310ER-GM	£17.00	40
MFH18-M08-03-2T	18	LOGU030310ER-GM	£18.00	40
MFH20-M10-03-3T	20	LOGU030310ER-GM	£20.00	40
MFH20-M10-03-4T	20	LOGU030310ER-GM	£20.00	40
MFH22-M10-03-3T	22	LOGU030310ER-GM	£22.00	40
MFH22-M10-03-4T	22	LOGU030310ER-GM	£22.00	40
MFH25-M12-03-4T	25	LOGU030310ER-GM	£25.00	40
MFH25-M12-03-5T	25	LOGU030310ER-GM	£25.00	40
MFH28-M12-03-4T	28	LOGU030310ER-GM	£28.00	40
MFH28-M12-03-5T	28	LOGU030310ER-GM	£28.00	40
MFH32-M16-03-5T	32	LOGU030310ER-GM	£32.00	40
MFH32-M16-03-6T	32	LOGU030310ER-GM	£32.00	40



Shape	Description
	LOGU030310ER-GM PR1825

Choose the insert grade to suit the material being machined!

P	Steel	★
	Die steel	★
M	Austenitic stainless steel	★ ☆
	Martensitic stainless steel	☆
	Precipitation hardened stainless steel	★
K	Gray cast iron	★
	Nodular cast iron	★
N	Non-ferrous material	
S	Heat-resistant alloy	★
	Titanium alloy	★
H	Hardened material	☆

Insert grades



PR1835 PR1825 PR1810

ORDERING EXAMPLE

16 mm Dia Cutter
MFH16-M08-03-2T

+

Inserts
LOGU030310ER-GM PR1825

Purchasing price
= £16 + 40 inserts

MFH Boost high feed cutter

HIGH EFFICIENCY END MILLING CUTTER FOR VARIOUS APPLICATIONS



LOGU 04 insert type

	Cutter Description	Cutting Diameter	Insert Description	Special Cutter Body price	Number of inserts required for Special promotion
Standard Shank	MFH22-S20-04-2T	22	LOMU 040410ER-GM	£22,00	30
	MFH25-S25-04-2T	25	LOMU 040410ER-GM	£25,00	30
	MFH25-S25-04-3T	25	LOMU 040410ER-GM	£25,00	30
	MFH28-S25-04-3T	28	LOMU 040410ER-GM	£28,00	40
Over sized Shank	MFH28-S25-04-4T	28	LOMU 040410ER-GM	£28,00	40
	MFH32-S32-04-4T	32	LOMU 040410ER-GM	£32,00	40
	MFH32-S32-04-5T	32	LOMU 040410ER-GM	£32,00	40
	MFH35-S32-04-4T	35	LOMU 040410ER-GM	£35,00	40
	MFH35-S32-04-5T	35	LOMU 040410ER-GM	£35,00	40
	MFH40-S32-04-5T	40	LOMU 040410ER-GM	£40,00	40
	MFH40-S32-04-6T	40	LOMU 040410ER-GM	£40,00	40
	MFH40-S32-04-5T-250	40	LOMU 040410ER-GM	£40,00	40
Weldon	MFH25-W25-04-2T	25	LOMU 040410ER-GM	£25,00	30
	MFH25-W25-04-3T	25	LOMU 040410ER-GM	£25,00	30
	MFH32-W32-04-4T	32	LOMU 040410ER-GM	£32,00	40
	MFH32-W32-04-5T	32	LOMU 040410ER-GM	£32,00	40
	MFH40-W32-04-5T	40	LOMU 040410ER-GM	£40,00	40
	MFH40-W32-04-6T	40	LOMU 040410ER-GM	£40,00	40
Long Shank	MFH25-S25-04-2T-180	25	LOMU 040410ER-GM	£25,00	40
	MFH25-S25-04-3T-180	25	LOMU 040410ER-GM	£25,00	40
	MFH28-S25-04-3T-200	28	LOMU 040410ER-GM	£28,00	40
	MFH32-S32-04-4T-200	32	LOMU 040410ER-GM	£32,00	40
	MFH35-S32-04-4T-200	35	LOMU 040410ER-GM	£35,00	40
	MFH40-S32-04-5T-250	40	LOMU 040410ER-GM	£40,00	50

	Material	☆	★	
P	Steel	☆	★	
	Die steel	☆	★	
M	Austenitic stainless steel	★	☆	
	Martensitic stainless steel	☆		★
	Precipitation hardened stainless steel	★		
K	Gray cast iron			★
	Nodular cast iron			★
N	Non-ferrous material			
S	Heat-resistant alloy	☆		★
	Titanium alloy	★		
H	Hardened material			

Insert grades		CVD Coating
	PR1835 PR1825 PR1810	CA6535

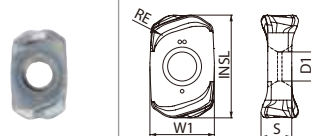
Shape	Description
	LOMU040410ER-GM PR1825

Choose the insert grade to suit the material being machined!

ORDERING EXAMPLE	
22 mm Dia Cutter MFH22-S20-04-2T	+ Inserts LOMU040410ER-GM PR1825
Purchasing price = £22 + 30 inserts	



MFH Boost high feed cutter

HIGH EFFICIENCY FACE MILLING CUTTER FOR VARIOUS APPLICATIONS

LOGU 04 insert type

Cutter Description	Cutting Diameter	Insert Description	Special Cutter Body price	Number of inserts required for Special promotion
MFH040R-04-5T-M	40	LOMU 040410ER-GM	£40,00	50
MFH040R-04-6T-M	40	LOMU 040410ER-GM	£40,00	50
MFH050R-04-6T-M	50	LOMU 040410ER-GM	£50,00	50
MFH050R-04-7T-M	50	LOMU 040410ER-GM	£50,00	50
MFH052R-04-6T-M	52	LOMU 040410ER-GM	£52,00	50
MFH052R-04-7T-M	52	LOMU 040410ER-GM	£52,00	50
MFH063R-04-7T-M	63	LOMU 040410ER-GM	£63,00	60
MFH063R-04-9T-M	63	LOMU 040410ER-GM	£63,00	60
MFH063R-04-7T-27M	63	LOMU 040410ER-GM	£63,00	60
MFH063R-04-9T-27M	63	LOMU 040410ER-GM	£63,00	60
MFH080R-04-8T-M	80	LOMU 040410ER-GM	£80,00	70
MFH080R-04-10T-M	80	LOMU 040410ER-GM	£80,00	70



Shape	Description
	LOMU040410ER-GM PR1825

Choose the insert grade to suit the material being machined!

P	Steel	☆	★	
	Die steel	☆	★	
M	Austenitic stainless steel	★	☆	
	Martensitic stainless steel	☆		★
	Precipitation hardened stainless steel	★		
K	Gray cast iron			★
	Nodular cast iron			★
N	Non-ferrous material			
S	Heat-resistant alloy	☆		★
	Titanium alloy	★		
H	Hardened material			
Insert grades				
				CVD Coating
		PR1835	PR1825	PR1810
				CA6535

ORDERING EXAMPLE

40 mm Dia Cutter
MFH040R-04-5T-M

+
Inserts

LOMU040410ER-GM PR1825

**Purchasing price
= £40 + 50 inserts**



MFH Boost high feed cutter

HIGH EFFICIENCY MODULAR MILLING CUTTER FOR VARIOUS APPLICATIONS

LOGU 04 insert type

Cutter Description	Cutting Diameter	Insert Description	Special Cutter Body price	Number of inserts required for Special promotion
MFH22-M10-04-2T	22	LOMU 040410ER-GM	£22,00	30
MFH25-M12-04-2T	25	LOMU 040410ER-GM	£25,00	30
MFH25-M12-04-3T	25	LOMU 040410ER-GM	£25,00	30
MFH28-M12-04-3T	28	LOMU 040410ER-GM	£28,00	40
MFH28-M12-04-4T	28	LOMU 040410ER-GM	£28,00	40
MFH32-M16-04-4T	32	LOMU 040410ER-GM	£32,00	40
MFH32-M16-04-5T	32	LOMU 040410ER-GM	£32,00	40
MFH35-M16-04-4T	35	LOMU 040410ER-GM	£35,00	40
MFH35-M16-04-5T	35	LOMU 040410ER-GM	£35,00	40
MFH40-M16-04-5T	40	LOMU 040410ER-GM	£40,00	40
MFH40-M16-04-6T	40	LOMU 040410ER-GM	£40,00	40
MFH42-M16-04-5T	42	LOMU 040410ER-GM	£42,00	40
MFH42-M16-04-6T	42	LOMU 040410ER-GM	£42,00	40



Shape	Description
	LOMU040410ER-GM PR1825

Choose the insert grade to suit the material being machined!

P	Steel	☆	★	
	Die steel	☆	★	
M	Austenitic stainless steel	★	☆	
	Martensitic stainless steel	☆		★
	Precipitation hardened stainless steel	★		
K	Gray cast iron			★
	Nodular cast iron			★
N	Non-ferrous material			
S	Heat-resistant alloy	☆		★
	Titanium alloy	★		
H	Hardened material			

Insert grades

			CVD Coating
PR1835	PR1825	PR1810	CA6535

ORDERING EXAMPLE

22 mm Dia Cutter
MFH22-M10-04-2T

+
Inserts
LOMU040410ER-GM PR1825

Purchasing price
= £22 + 30 inserts

MA90

TANGENTIAL 90° END MILL/MULTI-FUNCTION

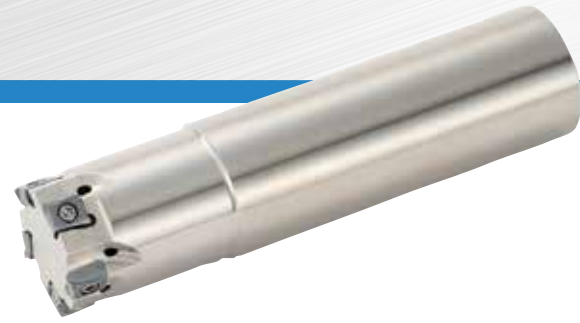

LOGU 09 insert type

	Cutter Description	Cutting Diameter	Insert Description	Special Cutter Body price	Number of inserts required for Special promotion
Standard Shank	MA90-16S12-09T2C	16	LOGU 090408ER-GM	£16,00	40
	MA90-18S16-09T2C	18	LOGU 090408ER-GM	£18,00	40
	MA90-20S16-09T2C	20	LOGU 090408ER-GM	£20,00	40
	MA90-20S16-09T3C	20	LOGU 090408ER-GM	£20,00	40
	MA90-22S20-09T3C	22	LOGU 090408ER-GM	£22,00	40
	MA90-25S20-09T3C	25	LOGU 090408ER-GM	£25,00	40
	MA90-25S20-09T4C	25	LOGU 090408ER-GM	£25,00	40
	MA90-28S25-09T3C	28	LOGU 090408ER-GM	£28,00	40
	MA90-30S25-09T4C	30	LOGU 090408ER-GM	£30,00	40
	MA90-32S25-09T4C	32	LOGU 090408ER-GM	£32,00	40
	MA90-32S25-09T5C	32	LOGU 090408ER-GM	£32,00	40
	MA90-35S32-09T4C	35	LOGU 090408ER-GM	£35,00	40
	MA90-35S32-09T5C	35	LOGU 090408ER-GM	£35,00	50
	MA90-40S32-09T4C	40	LOGU 090408ER-GM	£40,00	50
	MA90-40S32-09T6C	40	LOGU 090408ER-GM	£40,00	50
	MA90-50S32-09T5C	50	LOGU 090408ER-GM	£50,00	60
MA90-50S32-09T7C	50	LOGU 090408ER-GM	£50,00	60	
Same size Shank	MA90-16S16-09T2C	16	LOGU 090408ER-GM	£16,00	40
	MA90-20S20-09T2C	20	LOGU 090408ER-GM	£20,00	40
	MA90-20S20-09T3C	20	LOGU 090408ER-GM	£20,00	40
	MA90-25S25-09T3C	25	LOGU 090408ER-GM	£25,00	40
	MA90-25S25-09T4C	25	LOGU 090408ER-GM	£25,00	40
	MA90-32S32-09T4C	32	LOGU 090408ER-GM	£32,00	40
	MA90-32S32-09T5C	32	LOGU 090408ER-GM	£32,00	40
Long Shank	MA90-20S18-09T2CL	20	LOGU 090408ER-GM	£20,00	40
	MA90-20S20-09T2CL	20	LOGU 090408ER-GM	£20,00	40
	MA90-25S25-09T2CL	25	LOGU 090408ER-GM	£25,00	40
	MA90-32S32-09T2CL	32	LOGU 090408ER-GM	£32,00	40

P	Steel	★	☆			
	Die steel	★	☆			
M	Austenitic stainless steel		★	☆		
	Martensitic stainless steel		☆	★		
	Precipitation hardened stainless steel		★			
K	Gray cast iron			★		
	Nodular cast iron			★		
N	Non-ferrous material					
S	Heat-resistant alloy		☆	★		
	Titanium alloy		★			
H	Hardened material			★		
Insert grades				CVD Coating		
		PR1825	PR1835	PR1810	PR0155	CA6535



Shape	Description
	LOGU090408ER-GM PR1825
<p>Choose the insert grade to suit the material being machined!</p> <p>Unmarked : GM △ : SM □ : GH</p>	
<p>ORDERING EXAMPLE</p> <p>16 mm Dia Cutter + Inserts MA90-16S12-09T2C + LOGU090408ER-GM PR1825</p> <p>Purchasing price = £16 + 40 inserts</p>	

MA90

TANGENTIAL 90° END MILL/MULTI-FUNCTION



LOGU 12 insert type

	Cutter Description	Cutting Diameter	Insert Description	Special Cutter Body price	Number of inserts required for Special promotion
Standard Shank	MA90-25S20-12T2C	25	LOGU 120608ER-GM	£25,00	40
	MA90-28S25-12T2C	28	LOGU 120608ER-GM	£28,00	40
	MA90-30S25-12T2C	30	LOGU 120608ER-GM	£30,00	40
	MA90-30S25-12T3C	30	LOGU 120608ER-GM	£30,00	40
	MA90-32S25-12T2C	32	LOGU 120608ER-GM	£32,00	40
	MA90-32S25-12T3C	32	LOGU 120608ER-GM	£32,00	40
	MA90-35S32-12T3C	35	LOGU 120608ER-GM	£35,00	40
	MA90-40S32-12T3C	40	LOGU 120608ER-GM	£40,00	50
	MA90-40S32-12T4C	40	LOGU 120608ER-GM	£40,00	50
	MA90-50S32-12T4C	50	LOGU 120608ER-GM	£50,00	50
	MA90-50S32-12T6C	50	LOGU 120608ER-GM	£50,00	50
Same size Shank	MA90-25S25-12T2C	25	LOGU 120608ER-GM	£25,00	40
	MA90-32S32-12T2C	32	LOGU 120608ER-GM	£32,00	40
	MA90-32S32-12T3C	32	LOGU 120608ER-GM	£32,00	40
Long Shank	MA90-25S25-12T2CL	25	LOGU 120608ER-GM	£25,00	40
	MA90-32S32-12T2CL	32	LOGU 120608ER-GM	£32,00	40

P	Steel	★	☆	
	Die steel	★	☆	
M	Austenitic stainless steel		★	☆
	Martensitic stainless steel		☆	★
	Precipitation hardened stainless steel		★	
K	Gray cast iron			★
	Nodular cast iron			★
N	Non-ferrous material			
S	Heat-resistant alloy		☆	★
	Titanium alloy		★	
H	Hardened material			★
Insert grades				CVD Coating
PR1825 PR1835 PR1810 PR015S				CA6535



Shape	Description
	LOGU120608ER-GM PR1825

Choose the insert grade to suit the material being machined!

Unmarked : GM △ : SM □ : GH

ORDERING EXAMPLE	
25 mm Dia Cutter MA90-25S20-12T2C	+ Inserts LOGU120608ER-GM PR1825
Purchasing price = £25 + 40 inserts	

MA90

TANGENTIAL 90° FACE MILL/MULTI-FUNCTION





LOGU 09 insert type

Cutter Description	Cutting Diameter	Insert Description	Special Cutter Body price	Number of inserts required for Special promotion
MA90-040R-09T4C-M	40	LOGU 090408ER-GM	£40,00	50
MA90-040R-09T6C-M	40	LOGU 090408ER-GM	£40,00	50
MA90-050R-09T5C-M	50	LOGU 090408ER-GM	£50,00	50
MA90-050R-09T7C-M	50	LOGU 090408ER-GM	£50,00	50
MA90-063R-09T6C-M	63	LOGU 090408ER-GM	£63,00	60
MA90-063R-09T9C-M	63	LOGU 090408ER-GM	£63,00	60

LOGU 12 insert type

Cutter Description	Cutting Diameter	Insert Description	Special Cutter Body price	Number of inserts required for Special promotion
MA90-040R-12T3C-M	40	LOGU 120608ER-GM	£40,00	50
MA90-040R-12T4C-M	40	LOGU 120608ER-GM	£40,00	50
MA90-050R-12T4C-M	50	LOGU 120608ER-GM	£50,00	50
MA90-050R-12T6C-M	50	LOGU 120608ER-GM	£50,00	50
MA90-063R-12T6C-M	63	LOGU 120608ER-GM	£63,00	50
MA90-063R-12T8C-M	63	LOGU 120608ER-GM	£63,00	50
MA90-080R-12T7C-M	80	LOGU 120608ER-GM	£80,00	60
MA90-080R-12T10C-M	80	LOGU 120608ER-GM	£80,00	60
MA90-100R-12T9C-M	100	LOGU 120608ER-GM	£100,00	70
MA90-100R-12T13C-M	100	LOGU 120608ER-GM	£100,00	70
MA90-125R-12T12C-M	125	LOGU 120608ER-GM	£125,00	80
MA90-125R-12T16C-M	125	LOGU 120608ER-GM	£125,00	80

P	Steel	★	☆	
	Die steel	★	☆	
M	Austenitic stainless steel		★	☆
	Martensitic stainless steel		☆	★
	Precipitation hardened stainless steel		★	
K	Gray cast iron			★
	Nodular cast iron			★
N	Non-ferrous material			
S	Heat-resistant alloy		☆	★
	Titanium alloy		★	
H	Hardened material			★
Insert grades				 PR1825 PR1835 PR1810 PR0155 CA6535
				CVD Coating

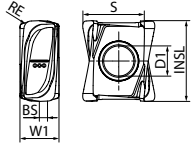
Shape	Description
	LOGU 090408ER-GM PR1825
	LOGU 120608ER-GM PR1825

Choose the insert grade to suit the material being machined!

Unmarked : GM △ : SM □ : GH

ORDERING EXAMPLE	
40 mm Dia Cutter MA90-040R-09T4C-M	+ Inserts LOGU 090408ER-GM PR1825
Purchasing price = £40 + 50 inserts	

MA90

TANGENTIAL 90° MODULAR MILL/MULTI-FUNCTION



LOGU 09 insert type

Cutter Description	Cutting Diameter	Insert Description	Special Cutter Body price	Number of inserts required for Special promotion
MA90-20M10-09T2C	20	LOGU 090408ER-GM	£20,00	40
MA90-20M10-09T3C	20	LOGU 090408ER-GM	£20,00	40
MA90-25M12-09T3C	25	LOGU 090408ER-GM	£25,00	40
MA90-25M12-09T4C	25	LOGU 090408ER-GM	£25,00	40
MA90-32M16-09T4C	32	LOGU 090408ER-GM	£32,00	40
MA90-32M16-09T5C	32	LOGU 090408ER-GM	£32,00	40

LOGU 12 insert type

Cutter Description	Cutting Diameter	Insert Description	Special Cutter Body price	Number of inserts required for Special promotion
MA90-25M12-12T2C	25	LOGU 120608ER-GM	£25,00	40
MA90-32M16-12T2C	25	LOGU 120608ER-GM	£32,00	40
MA90-32M16-12T3C	32	LOGU 120608ER-GM	£32,00	40

P	Steel	★	☆	
	Die steel	★	☆	
M	Austenitic stainless steel		★	☆
	Martensitic stainless steel		☆	★
	Precipitation hardened stainless steel		★	
K	Gray cast iron			★
	Nodular cast iron			★
N	Non-ferrous material			
S	Heat-resistant alloy		☆	★
	Titanium alloy		★	
H	Hardened material			★
Insert grades 				CVD Coating PR1825 PR1835 PR1810 PR015S CA6535

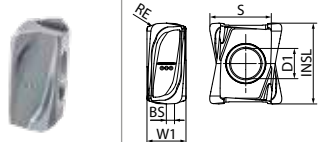
Shape	Description
	LOGU 090408ER-GM PR1825 LOGU 120608ER-GM PR1825

Choose the insert grade to suit the material being machined!

Unmarked : GM △ : SM □ : GH

ORDERING EXAMPLE	
20 mm Dia Cutter MA90-20M10-09T2C	+ Inserts LOGU 090408ER-GM PR1825
Purchasing price = £20 + 40 inserts	

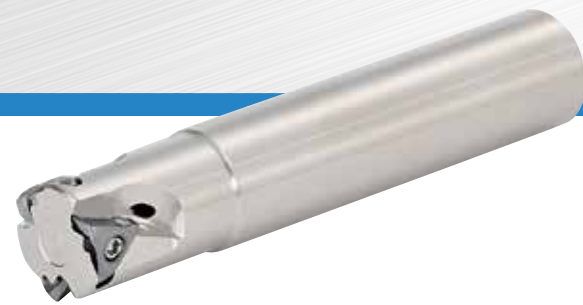

MEV

HIGH PERFORMANCE, MULTI-FUNCTIONAL END MILLING CUTTERS

TOMT06 insert type

	Cutter Description	Cutting Diameter	Insert Description	Special Cutter Body price	Number of inserts required for Special promotion
Standard Shank	MEV20-S16-06-2T	20	TOMT060508ER-GM	£20,00	40
	MEV22-S20-06-3T	22	TOMT060508ER-GM	£22,00	40
	MEV25-S20-06-3T	25	TOMT060508ER-GM	£25,00	40
	MEV28-S25-06-3T	28	TOMT060508ER-GM	£28,00	40
	MEV30-S25-06-4T	30	TOMT060508ER-GM	£30,00	40
	MEV32-S25-06-4T	32	TOMT060508ER-GM	£32,00	40
	MEV40-S32-06-5T	40	TOMT060508ER-GM	£40,00	40
	MEV50-S32-06-5T	50	TOMT060508ER-GM	£50,00	40
Same size Shank	MEV20-S20-06-2T	20	TOMT060508ER-GM	£20,00	40
	MEV20-S20-06-3T	20	TOMT060508ER-GM	£20,00	40
	MEV25-S25-06-2T	25	TOMT060508ER-GM	£25,00	40
	MEV25-S25-06-3T	25	TOMT060508ER-GM	£25,00	40
	MEV32-S32-06-3T	32	TOMT060508ER-GM	£32,00	40
	MEV32-S32-06-4T	32	TOMT060508ER-GM	£32,00	40
Long Shank	MEV20-S18-06-150-2T	20	TOMT060508ER-GM	£20,00	40
	MEV20-S20-06-150-2T	20	TOMT060508ER-GM	£20,00	40
	MEV25-S25-06-170-2T	25	TOMT060508ER-GM	£32,00	40
	MEV32-S32-06-200-2T	32	TOMT060508ER-GM	£20,00	40
Long Shank (Fine pitch)	MEV20-S18-06-150-3T	20	TOMT060508ER-GM	£20,00	40
	MEV20-S20-06-150-3T	20	TOMT060508ER-GM	£20,00	40
	MEV25-S25-06-170-3T	25	TOMT060508ER-GM	£25,00	40
	MEV32-S32-06-200-3T	32	TOMT060508ER-GM	£32,00	40

P	Steel	☆	★	
	Die steel	☆	★	
M	Austenitic stainless steel	★	☆	☆
	Martensitic stainless steel	☆		★
	Precipitation hardened stainless steel	★		
K	Gray cast iron		☆	★
	Nodular cast iron		☆	★
N	Non-ferrous material			
S	Heat-resistant alloy	☆		★
	Titanium alloy	★		☆
H	Hardened material			□
Insert grades				
		PR1835	PR1825	PR1810
				CA6535
				CVD Coating

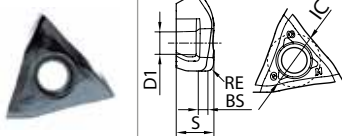
Shape	Description
	TOMT060508ER-GM PR1835
<p>Choose the insert grade to suit the material being machined!</p> <p>Unmarked : GM △ : SM □ : GH</p>	
<p>ORDERING EXAMPLE</p>	
<p>20 mm Dia Cutter + Inserts MEV20-S16-06-2T + TOMT060508ER-GM PR1835</p>	
<p>Purchasing price = £20 + 40 inserts</p>	



MEV

HIGH PERFORMANCE, MULTI-FUNCTIONAL FACE MILLING CUTTERS

TOMT06 insert type

Cutter Description	Cutting Diameter	Insert Description	Special Cutter Body price	Number of inserts required for Special promotion
MEV032R-06-4T-M	32	TOMT060508ER-GM	£32,00	40
MEV040R-06-5T-M	40	TOMT060508ER-GM	£40,00	40
MEV050R-06-5T-M	50	TOMT060508ER-GM	£50,00	60
MEV063R-06-6T-M	63	TOMT060508ER-GM	£63,00	60
MEV080R-06-7T-M	80	TOMT060508ER-GM	£80,00	80
MEV100R-06-9T-M	100	TOMT060508ER-GM	£100,00	100



MEV

HIGH PERFORMANCE, MULTI-FUNCTIONAL MODULAR MILLING CUTTERS

TOMT06 insert type

Cutter Description	Cutting Diameter	Insert Description	Special Cutter Body price	Number of inserts required for Special promotion
MEV20-M10-06-2T	20	TOMT060508ER-GM	£20,00	40
MEV20-M10-06-3T	20	TOMT060508ER-GM	£20,00	40
MEV25-M12-06-3T	25	TOMT060508ER-GM	£25,00	40
MEV32-M16-06-4T	32	TOMT060508ER-GM	£32,00	40

P	Steel	☆	★		
	Die steel	☆	★		
M	Austenitic stainless steel	★	☆	☆	
	Martensitic stainless steel	☆		★	
K	Precipitation hardened stainless steel	★			
	Gray cast iron		☆	★	
N	Nodular cast iron		☆	★	
	Non-ferrous material				
S	Heat-resistant alloy	☆		★	
	Titanium alloy	★		☆	
H	Hardened material			□	
Insert grades				CVD Coating	
		PR1835	PR1825	PR1810	CA6535

Shape	Description
	TOMT060508ER-GM PR1835

Choose the insert grade to suit the material being machined!

Unmarked : GM △ : SM □ : GH

ORDERING EXAMPLE	
32 mm Dia Cutter MEV032R-06-4T-M	+ Inserts TOMT060508ER-GM PR1835
Purchasing price = £32 + 40 inserts	

MEC

BDGT STYLE OF INSERTS AVAILABLE FOR ALUMINIUM



BDMT11T3 insert type

Cutter Description	Cutting Diameter	Insert Description	Special Cutter Body price	Number of inserts required for Special promotion
MEC040R-11-5T-M	40	BDMT11T308ER-JT	£40.00	40
MEC050R-11-7T-M	50	BDMT11T308ER-JT	£50.00	60
MEC050R-11-5T-M	50	BDMT11T308ER-JT	£50.00	40
MEC063R-11-6T-M	63	BDMT11T308ER-JT	£63.00	50
MEC063R-11-8T-M	63	BDMT11T308ER-JT	£63.00	80
MEC080R-11-7T-M	80	BDMT11T308ER-JT	£80.00	90
MEC100R-11-9T-MN	100	BDMT11T308ER-JT	£100.00	100
MEC125R-11-11T-M	125	BDMT11T308ER-JT	£125.00	120
MEC160R-11-14T-M	160	BDMT11T308ER-JT	£160.00	160

BDMT1704 insert type

Cutter Description	Cutting Diameter	Insert Description	Special Cutter Body price	Number of inserts required for Special promotion
MEC040R-17-4T-M	40	BDMT170408ER-JT	£40.00	40
MEC050R-17-5T-M	50	BDMT170408ER-JT	£50.00	50
MEC050R-17-4T-M	50	BDMT170408ER-JT	£50.00	40
MEC063R-17-6T-M	63	BDMT170408ER-JT	£63.00	60
MEC063R-17-5T-M	63	BDMT170408ER-JT	£63.00	50
MEC080R-17-6T-M	80	BDMT170408ER-JT	£80.00	50
MEC100R-17-7T-MN	100	BDMT170408ER-JT	£100.00	60
MEC125R-17-9T-M	125	BDMT170408ER-JT	£125.00	100
MEC160R-17-12T-M	160	BDMT170408ER-JT	£160.00	140

P	Steel	★
	Die steel	★
M	Austenitic stainless steel	★ ☆
	Martensitic stainless steel	☆
	Precipitation hardened stainless steel	★
K	Gray cast iron	★
	Nodular cast iron	★
N	Non-ferrous material	
S	Heat-resistant alloy	★
	Titanium alloy	★
H	Hardened material	☆

Insert grades



PR1835 PR1825 PR1810

Shape	Description
	BDMT11T308ER-JT PR1825 or BDMT170408ER-JT PR1825

Choose the insert grade to suit the material being machined!

ORDERING EXAMPLE

40 mm Dia Cutter + **Inserts**
MEC040R-11-5T-M + BDMT11T308ER-JT PR1825

Purchasing price = £40 + 40 inserts

MEC

BDGT STYLE OF INSERTS AVAILABLE FOR ALUMINIUM



BDMT11T3 insert type

	Cutter Description	Cutting Diameter	Number of inserts	Insert Description	Special Cutter Body price	Number of inserts required for Special promotion
Standard Shank	MEC16-S12-11T	16	2	BDMT11T308ER-JT	£16.00	40
	MEC17-S16-11T	17	2	BDMT11T308ER-JT	£17.00	40
	MEC18-S16-11T	18	2	BDMT11T308ER-JT	£18.00	40
	MEC19-S16-11T	19	3	BDMT11T308ER-JT	£19.00	40
	MEC20-S16-11T	20	3	BDMT11T308ER-JT	£20.00	40
	MEC21-S20-11T	21	3	BDMT11T308ER-JT	£21.00	40
	MEC22-S20-11T	22	3	BDMT11T308ER-JT	£22.00	40
	MEC24-S20-11T	24	3	BDMT11T308ER-JT	£24.00	40
	MEC25-S20-11T	25	3	BDMT11T308ER-JT	£25.00	40
	MEC28-S25-11T	28	3	BDMT11T308ER-JT	£28.00	40
	MEC30-S25-11T	30	4	BDMT11T308ER-JT	£30.00	40
	MEC32-S25-11T	32	4	BDMT11T308ER-JT	£32.00	40
	MEC40-S32-11T	40	5	BDMT11T308ER-JT	£40.00	40
MEC50-S32-11T	50	5	BDMT11T308ER-JT	£50.00	40	
Same Shank	MEC16-S16-11T	16	2	BDMT11T308ER-JT	£16.00	40
	MEC20-S20-11T	20	3	BDMT11T308ER-JT	£20.00	40
	MEC25-S25-11T	25	3	BDMT11T308ER-JT	£25.00	40
	MEC32-S32-11T	32	4	BDMT11T308ER-JT	£32.00	40

Continues on the next page >



Shape	Description
	BDMT11T308ER-JT PR1825

Choose the insert grade to suit the material being machined!

P	Steel	★
	Die steel	★
M	Austenitic stainless steel	★ ☆
	Martensitic stainless steel	☆
	Precipitation hardened stainless steel	★
K	Gray cast iron	★
	Nodular cast iron	★
N	Non-ferrous material	
S	Heat-resistant alloy	★
	Titanium alloy	★
H	Hardened material	☆

Insert grades



PR1835 PR1825 PR1810

ORDERING EXAMPLE

16 mm Dia Cutter
MEC16-S12-11T

+
Inserts

BDMT11T308ER-JT PR1825

**Purchasing price
= £16 + 40 inserts**

MEC

BDGT STYLE OF INSERTS AVAILABLE FOR ALUMINIUM



BDMT11T3 insert type

	Cutter Description	Cutting Diameter	Number of inserts	Insert Description	Special Cutter Body price	Number of inserts required for Special promotion
Long Shank	MEC20-S18-170-11T	20	2	BDMT11T308ER-JT	£20.00	40
	MEC20-S20-140-11T	20	2	BDMT11T308ER-JT	£20.00	40
	MEC20-S20-170-11T	20	2	BDMT11T308ER-JT	£20.00	40
	MEC22-S20-170-11T	22	2	BDMT11T308ER-JT	£22.00	40
	MEC25-S23-210-11T	25	2	BDMT11T308ER-JT	£25.00	40
	MEC25-S25-160-11T	25	2	BDMT11T308ER-JT	£25.00	40
	MEC25-S25-210-11T	25	2	BDMT11T308ER-JT	£25.00	40
	MEC28-S25-210-11T	28	2	BDMT11T308ER-JT	£28.00	40
	MEC32-S30-250-11T	32	2	BDMT11T308ER-JT	£32.00	40
	MEC32-S32-200-11T	32	2	BDMT11T308ER-JT	£32.00	40
	MEC32-S32-250-11T	32	2	BDMT11T308ER-JT	£32.00	40
	MEC35-S32-250-11T	35	2	BDMT11T308ER-JT	£35.00	40
	MEC40-S32-240-11T	40	2	BDMT11T308ER-JT	£40.00	40
Weldon standard Shank	MEC16-W12-11T3	16	2	BDMT11T308ER-JT	£16.00	40
	MEC18-W16-11T3-H	18	2	BDMT11T308ER-JT	£18.00	40
	MEC20-W16-11T3-H	20	3	BDMT11T308ER-JT	£20.00	40
	MEC22-W20-11T3-H	22	3	BDMT11T308ER-JT	£22.00	40
	MEC25-W20-11T3-H	25	3	BDMT11T308ER-JT	£25.00	40
	MEC28-W25-11T3-H	28	3	BDMT11T308ER-JT	£28.00	40
	MEC30-W25-11T3-H	30	4	BDMT11T308ER-JT	£30.00	40
	MEC32-W25-11T3-H	32	4	BDMT11T308ER-JT	£32.00	40
Weldon same Shank	MEC40-W32-11T3-H	40	5	BDMT11T308ER-JT	£40.00	40
	MEC16-W16-11T3-H	16	2	BDMT11T308ER-JT	£16.00	40
	MEC20-W20-11T3-H	20	3	BDMT11T308ER-JT	£20.00	40
	MEC25-W25-11T3-H	25	3	BDMT11T308ER-JT	£25.00	40
	MEC32-W32-11T3-H	32	4	BDMT11T308ER-JT	£32.00	40

P	Steel		★
	Die steel		★
M	Austenitic stainless steel	★	☆
	Martensitic stainless steel	☆	
	Precipitation hardened stainless steel	★	
K	Gray cast iron		★
	Nodular cast iron		★
N	Non-ferrous material		
S	Heat-resistant alloy	★	
	Titanium alloy	★	
H	Hardened material		☆

Insert grades

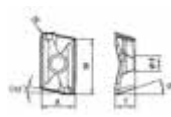

PR1835 PR1825 PR1810

Shape	Description
 	BDMT11T308ER-JT PR1825

Choose the insert grade to suit the material being machined!

ORDERING EXAMPLE	
16 mm Dia Cutter MEC16-S12-11T	+ Inserts BDMT11T308ER-JT PR1825
Purchasing price = £16 + 40 inserts	

MEC

BDGT STYLE OF INSERTS AVAILABLE FOR ALUMINIUM



BDMT1704 insert type

	Cutter Description	Cutting Diameter	Number of inserts	Insert Description	Special Cutter Body price	Number of inserts required for Special promotion
Standard Shank	MEC25-S20-17	25	2	BDMT170408ER-JT	£25.00	40
	MEC32-S25-17	32	3	BDMT170408ER-JT	£32.00	40
	MEC40-S32-17	40	4	BDMT170408ER-JT	£40.00	40
	MEC50-S32-17	50	4	BDMT170408ER-JT	£50.00	40
Same Shank	MEC25-S25-17	25	2	BDMT170408ER-JT	£25.00	40
	MEC32-S32-17	32	3	BDMT170408ER-JT	£32.00	40
Long Shank	MEC25-S25-160-17	25	2	BDMT170408ER-JT	£25.00	40
	MEC25-S25-210-17	25		BDMT170408ER-JT	£25.00	40
	MEC28-S25-210-17	28		BDMT170408ER-JT	£28.00	40
	MEC32-S32-200-17	32		BDMT170408ER-JT	£32.00	40
	MEC32-S32-250-17	32		BDMT170408ER-JT	£32.00	40
	MEC35-S32-250-17	35		BDMT170408ER-JT	£35.00	40
	MEC40-S32-240-17	40		BDMT170408ER-JT	£40.00	40
Weld on STD Shank	MEC25-W20-1704-H	25	2	BDMT170408ER-JT	£25.00	40
	MEC32-W25-1704-H	32	3	BDMT170408ER-JT	£32.00	40
	MEC40-W32-1704-H	40	4	BDMT170408ER-JT	£40.00	40
Weld on same Shank	MEC25-W25-1704-H	25	2	BDMT170408ER-JT	£25.00	40
	MEC32-W32-1704-H	32	3	BDMT170408ER-JT	£32.00	40



Shape	Description
	BDMT170408ER-JT PR1825

Choose the insert grade to suit the material being machined!

P	Steel	★
	Die steel	★
M	Austenitic stainless steel	★ ☆
	Martensitic stainless steel	☆
	Precipitation hardened stainless steel	★
K	Gray cast iron	★
	Nodular cast iron	★
N	Non-ferrous material	
S	Heat-resistant alloy	★
	Titanium alloy	★
H	Hardened material	☆

Insert grades



PR1835 PR1825 PR1810

ORDERING EXAMPLE

25 mm Dia Cutter
MEC25-S20-17

+
Inserts

BDMT170408ER-JT PR1825

**Purchasing price
= £25 + 40 inserts**

MEC

BDGT STYLE OF INSERTS AVAILABLE FOR ALUMINIUM



BDMT11T3 insert type

Cutter Description	Cutting Diameter	Insert Description	Special Cutter Body price	Number of inserts required for Special promotion
MEC16-M08-11T-2T	16	BDMT11T308ER-JT	£16.00	40
MEC20-M10-11T-2T	20	BDMT11T308ER-JT	£20.00	40
MEC20-M10-11T-3T	20	BDMT11T308ER-JT	£20.00	40
MEC25-M12-11T-3T	25	BDMT11T308ER-JT	£25.00	40
MEC32-M16-11T-4T	32	BDMT11T308ER-JT	£32.00	40

BDMT1704 insert type

Cutter Description	Cutting Diameter	Insert Description	Special Cutter Body price	Number of inserts required for Special promotion
MEC25-M12-17-2T	25	BDMT170408ER-JT	£25.00	40
MEC32-M16-17-3T	32	BDMT170408ER-JT	£32.00	40



Shape	Description
	BDMT11T308ER-JT PR1825 or BDMT170408ER-JT PR1825

Choose the insert grade to suit the material being machined!

P	Steel	★
	Die steel	★
M	Austenitic stainless steel	★ ☆
	Martensitic stainless steel	☆
	Precipitation hardened stainless steel	★
K	Gray cast iron	★
	Nodular cast iron	★
N	Non-ferrous material	
S	Heat-resistant alloy	★
	Titanium alloy	★
H	Hardened material	☆

Insert grades



PR1835 PR1825 PR1810

ORDERING EXAMPLE

25 mm Dia Cutter
MEC25-M12-17-2T

+
Inserts
BDMT170408ER-JT PR1825

Purchasing price
= £25 + 40 inserts

MEC

MEC INSERTS FOR ALUMINIUM

BDGT11T3 insert type



Insert Description

Carbide Milling Insert BDGT11T302FR-JA GW25

Carbide Milling Insert BDGT11T304FR-JA GW25

Carbide Milling Insert BDGT11T308FR-JA GW25

Carbide Milling Insert BDGT11T302FR-JA PDL025

Carbide Milling Insert BDGT11T304FR-JA PDL025

Carbide Milling Insert BDGT11T308FR-JA PDL025

BDGT1704 insert type



Insert Description

Carbide Milling Insert BDGT170404FR-JA GW25

Carbide Milling Insert BDGT170408FR-JA GW25

Carbide Milling Insert BDGT170420FR-JA GW25

Carbide Milling Insert BDGT170431FR-JA GW25

Carbide Milling Insert BDGT170404FR-JA PDL025

Carbide Milling Insert BDGT170408FR-JA PDL025

Carbide Milling Insert BDGT170420FR-JA PDL025

Carbide Milling Insert BDGT170431FR-JA PDL025

Specifications

For cutting data and tool application please refer to the Kyocera Cutting Tools catalogue or contact your representative or Kyocera Unimerco Tooling Ltd.

Tel: 0114 278 8787

MEW

WITH LOMU1004 AND LOMU1505 INSERT TYPES



LOMU1004 insert type

Cutter Description	Cutting Diameter	Insert Description	Special Cutter Body price	Number of inserts required for Special promotion
MEW032R-10-4T-M	32	LOMU100408ER-GM	£32.00	40
MEW040R-10-5T-M	40	LOMU100408ER-GM	£40.00	40
MEW050R-10-5T-M	50	LOMU100408ER-GM	£50.00	40
MEW063R-10-6T-M	63	LOMU100408ER-GM	£63.00	40

LOMU1505 insert type

Cutter Description	Cutting Diameter	Insert Description	Special Cutter Body price	Number of inserts required for Special promotion
MEW040R-15-4T-M	40	LOMU150508ER-GM	£40.00	40
MEW050R-15-4T-M	50	LOMU150508ER-GM	£50.00	40
MEW063R-15-5T-M	63	LOMU150508ER-GM	£63.00	40
MEW080R-15-6T-M	80	LOMU150508ER-GM	£80.00	40



Shape	Description
	LOMU100408ER-GM PR1825 or LOMU150508ER-GM PR1825

Choose the insert grade to suit the material being machined!

P	Steel	★
	Die steel	★
M	Austenitic stainless steel	★ ☆
	Martensitic stainless steel	☆
	Precipitation hardened stainless steel	★
K	Gray cast iron	★
	Nodular cast iron	★
N	Non-ferrous material	
S	Heat-resistant alloy	★
	Titanium alloy	★
H	Hardened material	☆

Insert grades



PR1835 PR1825 PR1810

ORDERING EXAMPLE

32 mm Dia Cutter
MEW032R-10-4T-M

+
Inserts

LOMU100408ER-GM PR1825

Purchasing price
= £32 + 40 inserts

MEW

WITH LOMU1505 INSERT TYPES



LOMU1505 insert type

	Cutter Description	Cutting Diameter	Insert Description	Special Cutter Body price	Number of inserts required for Special promotion
Standard Shank	MEW25-S20-15-2T	25	LOMU150508ER-GM	£25.00	30
	MEW32-S25-15-2T	32	LOMU150508ER-GM	£32.00	30
	MEW40-S32-15-3T	40	LOMU150508ER-GM	£40.00	40
	MEW40-S32-15-4T	40	LOMU150508ER-GM	£40.00	40
	MEW50-S32-15-4T	50	LOMU150508ER-GM	£50.00	50
Same Shank	MEW25-S25-15-2T	25	LOMU150508ER-GM	£25.00	30
	MEW32-S32-15-2T	32	LOMU150508ER-GM	£32.00	30
	MEW32-S32-15-3T	32	LOMU150508ER-GM	£32.00	30
Weldon	MEW25-W25-15-2T	25	LOMU150508ER-GM	£25.00	30
	MEW32-W32-15-3T	32	LOMU150508ER-GM	£32.00	40
	MEW40-W32-15-4T	40	LOMU150508ER-GM	£40.00	40



Shape	Description
	LOMU150508ER-GM PR1825

Choose the insert grade to suit the material being machined!

P	Steel	★
	Die steel	★
M	Austenitic stainless steel	★ ☆
	Martensitic stainless steel	☆
	Precipitation hardened stainless steel	★
K	Gray cast iron	★
	Nodular cast iron	★
N	Non-ferrous material	
S	Heat-resistant alloy	★
	Titanium alloy	★
H	Hardened material	☆

Insert grades



PR1835 PR1825 PR1810

ORDERING EXAMPLE

25 mm Dia Cutter
MEW25-S20-15-2T

+

Inserts

LOMU150508ER-GM PR1825

Purchasing price
= £25 + 30 inserts

MEW

WITH LOMU1004 AND LOMU1505 INSERT TYPES



LOMU1004 insert type

Cutter Description	Cutting Diameter	Insert Description	Special Cutter Body price	Number of inserts required for Special promotion
MEW16-M08-10-2T	16	LOMU100408ER-GM	£16.00	30
MEW20-M10-10-2T	20	LOMU100408ER-GM	£20.00	30
MEW20-M10-10-3T	20	LOMU100408ER-GM	£20.00	30
MEW25-M12-10-3T	25	LOMU100408ER-GM	£25.00	40
MEW32-M16-10-4T	32	LOMU100408ER-GM	£32.00	40

LOMU1505 insert type

Cutter Description	Cutting Diameter	Insert Description	Special Cutter Body price	Number of inserts required for Special promotion
MEW25-M12-15-2T	25	LOMU150508ER-GM	£25.00	30
MEW32-M16-15-3T	32	LOMU150508ER-GM	£32.00	30



Shape	Description
	LOMU100408ER-GM PR1825 or LOMU150508ER-GM PR1825

Choose the insert grade to suit the material being machined!

P	Steel	★
	Die steel	★
M	Austenitic stainless steel	★ ☆
	Martensitic stainless steel	☆
	Precipitation hardened stainless steel	★
K	Gray cast iron	★
	Nodular cast iron	★
N	Non-ferrous material	
S	Heat-resistant alloy	★
	Titanium alloy	★
H	Hardened material	☆

Insert grades



PR1835 PR1825 PR1810

ORDERING EXAMPLE

16 mm Dia Cutter
MEW16-M08-10-2T

+

Inserts

LOMU100408ER-GM PR1825

Purchasing price
= £16 + 30 inserts

MEAS Aluminum Machining

HIGH SPEED END MILLS FOR ALUMINUM MACHINING



KCGT 13 insert type

	Cutter Description	Cutting Diameter	Insert Description	Special Cutter Body price	Number of inserts required for Special promotion
Straight shank	MEAS 25-S25-13-2T	25	KCGT 130508FR-AL PDL025	£25,00	40
	MEAS 28-S25-13-2T	28	KCGT 130508FR-AL PDL025	£28,00	40
	MEAS 32-S32-13-2T	32	KCGT 130508FR-AL PDL025	£32,00	40
	MEAS 35-S32-13-2T	35	KCGT 130508FR-AL PDL025	£35,00	40
	MEAS 40-S32-13-3T	40	KCGT 130508FR-AL PDL025	£40,00	40
	MEAS 25-S25-13-2T-170	25	KCGT 130508FR-AL PDL025	£25,00	40
	MEAS 32-S32-13-2T-200	32	KCGT 130508FR-AL PDL025	£32,00	40

Shape	Description
	KCGT 130504FR-AL PDL025 KCGT 130508FR-AL PDL025 KCGT 130512FR-AL PDL025 KCGT 130516FR-AL PDL025 KCGT 130520FR-AL PDL025 KCGT 130524FR-AL PDL025 KCGT 130530FR-AL PDL025 KCGT 130532FR-AL PDL025 KCGT 130540FR-AL PDL025 KCGT 130550FR-AL PDL025

AM Chipbreaker with tough edge

NEW

Shape	Description
	130504ER-AM PDL025 130508ER-AM PDL025 130516ER-AM PDL025 130525ER-AM PDL025 130530ER-AM PDL025 130540ER-AM PDL025

P	Steel	
	Die steel	
M	Austenitic stainless steel	
	Martensitic stainless steel	
	Precipitation hardened stainless steel	
K	Gray cast iron	
	Nodular cast iron	
N	Non-ferrous material (aluminum)	★
S	Heat-resistant alloy	
	Titanium alloy	
H	Hardened material	
Insert grades		DLC
		PDL025

ORDERING EXAMPLE

25 mm Dia Cutter
MEAS 25-S25-13-2T

+
Inserts

KCGT 130504FR-AL PDL025

Purchasing price
= £25 + 40 inserts

MEAS Aluminum Machining

HIGH SPEED FACE MILLS FOR ALUMINUM MACHINING



KCGT 13 insert type

Cutter Description	Cutting Diameter	Insert Description	Special Cutter Body price	Number of inserts required for Special promotion
MEAS 050R-13-4T-M	50	KCGT 130508FR-AL PDL025	£50.00	50

Shape	Description
	KCGT 130504FR-AL PDL025 KCGT 130508FR-AL PDL025 KCGT 130512FR-AL PDL025 KCGT 130516FR-AL PDL025 KCGT 130520FR-AL PDL025 KCGT 130524FR-AL PDL025 KCGT 130530FR-AL PDL025 KCGT 130532FR-AL PDL025 KCGT 130540FR-AL PDL025 KCGT 130550FR-AL PDL025

AM Chipbreaker with tough edge



Shape	Description
	130504ER-AM PDL025 130508ER-AM PDL025 130516ER-AM PDL025 130525ER-AM PDL025 130530ER-AM PDL025 130540ER-AM PDL025

P	Steel	
	Die steel	
	Austenitic stainless steel	
M	Martensitic stainless steel	
	Precipitation hardened stainless steel	
K	Gray cast iron	
	Nodular cast iron	
N	Non-ferrous material (aluminum)	★
	Heat-resistant alloy	
S	Titanium alloy	
H	Hardened material	
Insert grades		DLC
		PDL025

ORDERING EXAMPLE

50 mm Dia Cutter
MEAS 050R-13-4T-M

+

Inserts
KCGT 130504FR-AL PDL025

Purchasing price
= £50 + 50 inserts

MFWN

WITH WNMU 080608 INSERT TYPE



WNMU 080608 insert type

	Cutter Description	Cutting Diameter	Insert Description	Special Cutter Body price	Number of inserts required for Special promotion
Coarse Pitch	MFWN90063R-3T-M	63	WNMU 080608EN-GM	£63.00	50
	MFWN90080R-4T-M	80	WNMU 080608EN-GM	£80.00	60
	MFWN90100R-5T-M	100	WNMU 080608EN-GM	£100.00	60
	MFWN90125R-6T-M	125	WNMU 080608EN-GM	£125.00	80
	MFWN90160R-8T-M	160	WNMU 080608EN-GM	£160.00	80
	MFWN90200R-10T-M	200	WNMU 080608EN-GM	£200.00	120
	MFWN90250R-12T-M	250	WNMU 080608EN-GM	£250.00	140
Fine Pitch	MFWN90063R-4T-M	63	WNMU 080608EN-GM	£63.00	50
	MFWN90080R-5T-M	80	WNMU 080608EN-GM	£80.00	60
	MFWN90100R-7T-M	100	WNMU 080608EN-GM	£100.00	60
	MFWN90125R-8T-M	125	WNMU 080608EN-GM	£125.00	80
	MFWN90160R-10T-M	160	WNMU 080608EN-GM	£160.00	80
	MFWN90200R-12T-M	200	WNMU 080608EN-GM	£200.00	120
	MFWN90250R-14T-M	250	WNMU 080608EN-GM	£250.00	140
Extra fine Pitch	MFWN90063R-5T-M	63	WNMU 080608EN-GM	£63.00	50
	MFWN90080R-7T-M	80	WNMU 080608EN-GM	£80.00	60
	MFWN90100R-9T-M	100	WNMU 080608EN-GM	£100.00	60
	MFWN90125R-12T-M	125	WNMU 080608EN-GM	£125.00	80
	MFWN90160R-14T-M	160	WNMU 080608EN-GM	£160.00	80
	MFWN90200R-16T-M	200	WNMU 080608EN-GM	£200.00	120
	MFWN90250R-18T-M	250	WNMU 080608EN-GM	£250.00	140



Shape	Description
	WNMU080608EN-GM PR1825

Choose the insert grade to suit the material being machined!

P	Steel	★
	Die steel	★
M	Austenitic stainless steel	★ ☆
	Martensitic stainless steel	☆
	Precipitation hardened stainless steel	★
K	Gray cast iron	★
	Nodular cast iron	★
N	Non-ferrous material	
S	Heat-resistant alloy	★
	Titanium alloy	★
H	Hardened material	☆

Insert grades



PR1835 PR1825 PR1810

ORDERING EXAMPLE

63 mm Dia Cutter
MFWN90063R-3T-M

+
Inserts

WNMU080608EN-GM PR1825

Purchasing price
= £63 + 50 inserts

MFPN45

WITH PNMU1205ANER INSERT TYPES



PNMU1205ANER insert type

	Cutter Description	Cutting Diameter	Insert Description	Special Cutter Body price	Number of inserts required for Special promotion
Coarse Pitch	MFPN45063R-4T-M	63	PNMU1205ANER-GM	£63.00	40
	MFPN45080R-5T-M	80	PNMU1205ANER-GM	£80.00	40
	MFPN45100R-6T-M	100	PNMU1205ANER-GM	£100.00	50
	MFPN45125R-7T-M	125	PNMU1205ANER-GM	£125.00	60
	MFPN45160R-8T-M	160	PNMU1205ANER-GM	£160.00	80
	MFPN45200R-10T-M	200	PNMU1205ANER-GM	£200.00	100
	MFPN45250R-12T-M	250	PNMU1205ANER-GM	£250.00	120
	MFPN45315R-14T-M	315	PNMU1205ANER-GM	£315.00	300
Fine Pitch	MFPN45063R-5T-M	63	PNMU1205ANER-GM	£63.00	40
	MFPN45080R-6T-M	80	PNMU1205ANER-GM	£80.00	40
	MFPN45100R-8T-M	100	PNMU1205ANER-GM	£100.00	50
	MFPN45125R-10T-M	125	PNMU1205ANER-GM	£125.00	60
	MFPN45160R-12T-M	160	PNMU1205ANER-GM	£160.00	80
	MFPN45200R-14T-M	200	PNMU1205ANER-GM	£200.00	100
	MFPN45250R-16T-M	250	PNMU1205ANER-GM	£250.00	120
	MFPN45315R-18T-M	315	PNMU1205ANER-GM	£315.00	300
Extra fine pitch	MFPN45063R-6T-M	63	PNMU1205ANER-GM	£63.00	40
	MFPN45080R-8T-M	80	PNMU1205ANER-GM	£80.00	40
	MFPN45100R-10T-M	100	PNMU1205ANER-GM	£100.00	50
	MFPN45125R-13T-M	125	PNMU1205ANER-GM	£125.00	60
	MFPN45160R-16T-M	160	PNMU1205ANER-GM	£160.00	80
	MFPN45200R-18T-M	200	PNMU1205ANER-GM	£200.00	100
	MFPN45250R-20T-M	250	PNMU1205ANER-GM	£250.00	120

P	Steel	★
	Die steel	★
M	Austenitic stainless steel	★ ☆
	Martensitic stainless steel	☆
	Precipitation hardened stainless steel	★
K	Gray cast iron	★
	Nodular cast iron	★
N	Non-ferrous material	
S	Heat-resistant alloy	★
	Titanium alloy	★
H	Hardened material	☆

Insert grades



PR1835 PR1825 PR1810

Shape	Description
	PNMU1205ANER-GM PR1825

Choose the insert grade to suit the material being machined!

ORDERING EXAMPLE

63 mm Dia Cutter + **Inserts**
MFPN45063R-4T-M + PNMU1205ANER-GM PR1825

Purchasing price = £63 + 40 inserts

MB45

NEW 45° HIGH PERFORMANCE FACE MILLING CUTTER



SNMU 14 insert type

	Cutter Description	Cutting Diameter	Insert Description	Special Cutter Body price	Number of inserts required for Special promotion
Coarse pitch	MB45-040R-14T2C-M	40	SNMU1406ANER-GM	£40,00	40
	MB45-050R-14T3C-M	50	SNMU1406ANER-GM	£50,00	40
	MB45-063R-14T4C-M	63	SNMU1406ANER-GM	£63,00	50
	MB45-080R-14T5C-M	80	SNMU1406ANER-GM	£80,00	60
	MB45-100R-14T5C-M	100	SNMU1406ANER-GM	£100,00	60
	MB45-125R-14T6C-M	125	SNMU1406ANER-GM	£125,00	80
	MB45-160R-14T7-M	160	SNMU1406ANER-GM	£160,00	80
	MB45-200R-14T8-M	200	SNMU1406ANER-GM	£200,00	120
	MB45-250R-14T10-M	250	SNMU1406ANER-GM	£250,00	120
	MB45-315R-14T14-M	315	SNMU1406ANER-GM	£315,00	150
Fine pitch	MB45-040R-14T3C-M	40	SNMU1406ANER-GM	£40,00	40
	MB45-050R-14T4C-M	50	SNMU1406ANER-GM	£50,00	50
	MB45-063R-14T5C-M	63	SNMU1406ANER-GM	£63,00	50
	MB45-080R-14T6C-M	80	SNMU1406ANER-GM	£80,00	60
	MB45-100R-14T8C-M	100	SNMU1406ANER-GM	£100,00	80
	MB45-125R-14T10C-M	125	SNMU1406ANER-GM	£125,00	100
	MB45-160R-14T12-M	160	SNMU1406ANER-GM	£160,00	120
	MB45-200R-14T14-M	200	SNMU1406ANER-GM	£200,00	140
	MB45-250R-14T16-M	250	SNMU1406ANER-GM	£250,00	160
	MB45-315R-14T18-M	315	SNMU1406ANER-GM	£315,00	180
Extra fine pitch	MB45-040R-14T4C-M	40	SNMU1406ANER-GM	£40,00	40
	MB45-050R-14T5C-M	50	SNMU1406ANER-GM	£50,00	50
	MB45-063R-14T6C-M	63	SNMU1406ANER-GM	£63,00	60
	MB45-080R-14T8C-M	80	SNMU1406ANER-GM	£80,00	80
	MB45-100R-14T10C-M	100	SNMU1406ANER-GM	£100,00	100
	MB45-125R-14T13C-M	125	SNMU1406ANER-GM	£125,00	130
	MB45-160R-14T16-M	160	SNMU1406ANER-GM	£160,00	160
	MB45-200R-14T18-M	200	SNMU1406ANER-GM	£200,00	180
MB45-250R-14T20-M	250	SNMU1406ANER-GM	£250,00	200	

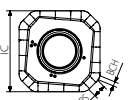
Shape	Description
 	SNMU1406ANER-GM SNMU1406ANER-GH SNEU1406ANER-GM SNEU1406ANER-SM SNEU1406ANFR-AM

Choose the insert grade to suit the material being machined!

ORDERING EXAMPLE

40 mm Dia Cutter
 MB45-040R-14T2C-M
 +
Inserts
 SNMU1406ANER-GM PR1825

Purchasing price
= £40 + 40 inserts

MB45

NEW 45° HIGH PERFORMANCE SHANK TYPE MILLING CUTTER



SNMU 14 insert type

Cutter Description	Cutting Diameter	Insert Description	Special Cutter Body price	Number of inserts required for Special promotion
MB45-40S32-14T2C	40	SNMU1406ANER-GM	£40,00	30
MB45-50S32-14T3C	50	SNMU1406ANER-GM	£50,00	40
MB45-63S32-14T4C	63	SNMU1406ANER-GM	£63,00	50
MB45-80S32-14T5C	80	SNMU1406ANER-GM	£80,00	50

Shape	Description
	 SNMU1406ANER-GM SNMU1406ANER-GH SNEU1406ANER-GM SNEU1406ANER-SM SNEU1406ANFR-AM

Choose the insert grade to suit the material being machined!

ORDERING EXAMPLE

40 mm Dia Cutter
 MB45-40S32-14T2C

+
Inserts
 SNMU1406ANER-GM PR1825

Purchasing price
= £40 + 30 inserts

P	Steel	★	☆				■		
	Die steel	★	☆				■		
M	Austenitic stainless steel	☆	★			★			
	Martensitic stainless steel		☆						
	Precipitation hardened stainless steel		★						
K	Gray cast iron			★					
	Nodular cast iron			★					
N	Non-ferrous material							★	☆
S	Heat-resistant alloy					★			
	Titanium alloy		★						
H	Hardened material				★				
Insert grades					MEGACOAT HARD	CVD	Cermet	DLC	uncoated
		PR1825	PR1835	PR1810	PR0155	CA6535	TN620M	PDL025	GW25

MRX

WITH RPMT10T3, RPMT1204 AND RPMT1605 INSERT TYPES



RPMT10T3 insert type

Cutter Description	Cutting Diameter	Insert Description	Special Cutter Body price	Number of inserts required for Special promotion
MRX040R-10-5T-M	40	RPMT10T3M0ER-GM	£40.00	60
MRX050R-10-6T-M	50	RPMT10T3M0ER-GM	£50.00	80
MRX063R-10-7T-M	63	RPMT10T3M0ER-GM	£63.00	100

RPMT1204 insert type

Cutter Description	Cutting Diameter	Insert Description	Special Cutter Body price	Number of inserts required for Special promotion
MRX040R-12-4T-M	40	RPMT1204M0ER-GM	£40.00	50
MRX050R-12-4T-M	50	RPMT1204M0ER-GM	£50.00	50
MRX050R-12-5T-M	50	RPMT1204M0ER-GM	£50.00	60
MRX052R-12-4T-M	52	RPMT1204M0ER-GM	£52.00	60
MRX052R-12-5T-M	52	RPMT1204M0ER-GM	£52.00	60
MRX066R-12-6T-M	66	RPMT1204M0ER-GM	£66.00	60
MRX063R-12-5T-M	63	RPMT1204M0ER-GM	£63.00	60
MRX063R-12-6T-M	63	RPMT1204M0ER-GM	£63.00	60
MRX080R-12-6T-M	80	RPMT1204M0ER-GM	£80.00	60
MRX080R-12-8T-M	80	RPMT1204M0ER-GM	£80.00	80
MRX100R-12-7T-M	100	RPMT1204M0ER-GM	£100.00	80
MRX100R-12-9T-M	100	RPMT1204M0ER-GM	£100.00	80

Continues on the next page >



Shape	Description
	RPMT10T3M0ER-GM PR1825 or RPMT1204M0ER-GM PR1825

Choose the insert grade to suit the material being machined!

P	Steel	★
	Die steel	★
M	Austenitic stainless steel	★ ☆
	Martensitic stainless steel	☆
	Precipitation hardened stainless steel	★
K	Gray cast iron	★
	Nodular cast iron	★
N	Non-ferrous material	
S	Heat-resistant alloy	★
	Titanium alloy	★
H	Hardened material	☆

Insert grades



PR1835 PR1825 PR1810

ORDERING EXAMPLE

40 mm Dia Cutter
MRX040R-12-4T-M

+
Inserts

RPMT1204M0ER-GM PR1825

Purchasing price
= £40 + 50 inserts

MRX

WITH RPMT10T3, RPMT1204 AND RPMT1605 INSERT TYPES



RPMT1605 insert type

Cutter Description	Cutting Diameter	Insert Description	Special Cutter Body price	Number of inserts required for Special promotion
MRX063R-16-4T-M	63	RPMT1605M0ER-GM	£63.00	40
MRX063R-16-5T-M	63	RPMT1605M0ER-GM	£63.00	40
MRX066R-16-4T-M	66	RPMT1605M0ER-GM	£66.00	40
MRX066R-16-5T-M	66	RPMT1605M0ER-GM	£66.00	40
MRX080R-16-5T-M	80	RPMT1605M0ER-GM	£80.00	40
MRX080R-16-6T-M	80	RPMT1605M0ER-GM	£80.00	50
MRX100R-16-6T-M	100	RPMT1605M0ER-GM	£100.00	50
MRX100R-16-7T-M	100	RPMT1605M0ER-GM	£100.00	60
MRX125R-16-6T-M	125	RPMT1605M0ER-GM	£125.00	50
MRX125R-16-8T-M	125	RPMT1605M0ER-GM	£125.00	60



Shape	Description
	RPMT1605M0ER-GM PR1825

Choose the insert grade to suit the material being machined!

P	Steel	★
	Die steel	★
M	Austenitic stainless steel	★ ☆
	Martensitic stainless steel	☆
	Precipitation hardened stainless steel	★
K	Gray cast iron	★
	Nodular cast iron	★
N	Non-ferrous material	
S	Heat-resistant alloy	★
	Titanium alloy	★
H	Hardened material	☆

Insert grades



PR1835 PR1825 PR1810

ORDERING EXAMPLE

40 mm Dia Cutter
MRX040R-12-4T-M

+
Inserts

RPMT1204M0ER-GM PR1825

Purchasing price
= £40 + 50 inserts

MRW

WITH ROMU1204 AND ROMU1605 INSERT TYPES



ROMU1204 insert type

Cutter Description	Cutting Diameter	Insert Description	Special Cutter Body price	Number of inserts required for Special promotion
MRW050R-12-5T-M	50	ROMU1204M0ER-GM	£50.00	50
MRW050R-12-6T-M	50	ROMU1204M0ER-GM	£50.00	50
MRW052R-12-5T-M	52	ROMU1204M0ER-GM	£52.00	50
MRW052R-12-6T-M	52	ROMU1204M0ER-GM	£52.00	50
MRW063R-12-6T-M	63	ROMU1204M0ER-GM	£63.00	60
MRW063R-12-7T-M	63	ROMU1204M0ER-GM	£63.00	60
MRW066R-12-6T-M	66	ROMU1204M0ER-GM	£66.00	60
MRW066R-12-7T-M	66	ROMU1204M0ER-GM	£66.00	60
MRW080R-12-6T-M	80	ROMU1204M0ER-GM	£80.00	60
MRW080R-12-8T-M	80	ROMU1204M0ER-GM	£80.00	60
MRW100R-12-7T-M	100	ROMU1204M0ER-GM	£100.00	60
MRW100R-12-9T-M	100	ROMU1204M0ER-GM	£100.00	70

ROMU1605 insert type

Cutter Description	Cutting Diameter	Insert Description	Special Cutter Body price	Number of inserts required for Special promotion
MRW063R-16-5T-M	63	ROMU1605M0ER-GM	£63.00	50
MRW063R-16-6T-M	63	ROMU1605M0ER-GM	£63.00	50
MRW066R-16-5T-M	66	ROMU1605M0ER-GM	£66.00	50
MRW066R-16-6T-M	66	ROMU1605M0ER-GM	£66.00	50
MRW080R-16-6T-M	80	ROMU1605M0ER-GM	£80.00	60
MRW080R-16-7T-M	80	ROMU1605M0ER-GM	£80.00	60
MRW100R-16-6T-M	100	ROMU1605M0ER-GM	£100.00	60
MRW100R-16-8T-M	100	ROMU1605M0ER-GM	£100.00	60
MRW125R-16-8T-M	125	ROMU1605M0ER-GM	£125.00	60
MRW125R-16-10T-M	125	ROMU1605M0ER-GM	£125.00	70

Material	Insert Grade	Star Rating
P	Steel	★
	Die steel	★
M	Austenitic stainless steel	★ ☆
	Martensitic stainless steel	☆
	Precipitation hardened stainless steel	★
K	Gray cast iron	★
	Nodular cast iron	★
N	Non-ferrous material	
S	Heat-resistant alloy	★
	Titanium alloy	★
H	Hardened material	☆

Insert grades



PR1835 PR1825 PR1810

Shape	Description
	ROMU1204M0ER-GM PR1825 or ROMU1605M0ER-GM PR1825

Choose the insert grade to suit the material being machined!

ORDERING EXAMPLE

50 mm Dia Cutter + **Inserts**
 MRW050R-12-5T-M + ROMU1204M0ER-GM PR1825
Purchasing price = £50 + 50 inserts

Vickers hardness conversion chart

Vickers hardness (HV)	Brinell hardness 10mm dia. ball Load: 3,000kgf (HB)		Rockwell hardness ²⁾			Shore hardness (HS)	Tensile strength MPa ¹⁾
	Standard ball	Tungsten carbide ball	A scale Load: 60kgf Diamond point (HRA)	B scale Load: 100kgf 1.6mm (1/16in) dia. ball (HRB)	C scale Load: 150kgf Diamond point (HRC)		
940	-	-	85.6	-	68.0	97	
920	-	-	85.3	-	67.5	96	
900	-	-	85.0	-	67.0	95	
880	-	(767)	84.7	-	66.4	93	
860	-	(757)	84.4	-	65.9	92	
840	-	(745)	84.1	-	65.3	91	
820	-	(733)	83.8	-	64.7	90	
800	-	(722)	83.4	-	64.0	88	
780	-	(710)	83.0	-	63.3	87	
760	-	(698)	82.6	-	62.5	86	
740	-	(684)	82.2	-	61.8	84	
720	-	(670)	81.8	-	61.0	83	
700	-	(656)	81.3	-	60.1	81	
690	-	(647)	81.1	-	59.7	-	
680	-	(638)	80.8	-	59.2	80	
670	-	630	80.6	-	58.8	-	
660	-	620	80.3	-	58.3	79	
650	-	611	80.0	-	57.8	-	
640	-	601	79.8	-	57.3	77	
630	-	591	79.5	-	56.8	-	
620	-	582	79.2	-	56.3	75	
610	-	573	78.9	-	55.7	-	
600	-	564	78.6	-	55.2	74	
590	-	554	78.4	-	54.7	-	2055
580	-	545	78.0	-	54.1	72	2020
570	-	535	77.8	-	53.6	-	1985
560	-	525	77.4	-	53.0	71	1950
550	505	517	77.0	-	52.3	-	1905
540	496	507	76.7	-	51.7	69	1860
530	488	497	76.4	-	51.1	-	1825
520	480	488	76.1	-	50.5	67	1795
510	473	479	75.7	-	49.8	-	1750
500	465	471	75.3	-	49.1	66	1705
490	456	460	74.9	-	48.4	-	1660
480	448	452	74.5	-	47.7	64	1620
470	441	442	74.1	-	46.9	-	1570
460	433	433	73.6	-	46.1	62	1530
450	425	425	73.3	-	45.3	-	1495
440	415	415	72.8	-	44.5	59	1460
430	405	405	72.3	-	43.6	-	1410
420	397	397	71.8	-	42.7	57	1370

Vickers hardness (HV)	Brinell hardness 10mm dia. ball Load: 3,000kgf (HB)		Rockwell hardness ²⁾			Shore hardness (HS)	Tensile strength MPa ¹⁾
	Standard ball	Tungsten carbide ball	A scale Load: 60kgf Diamond point (HRA)	B scale Load: 100kgf 1.6mm (1/16in) dia. ball (HRB)	C scale Load: 150kgf Diamond point (HRC)		
410	388	388	71.4	-	41.8	-	1330
400	379	379	70.8	-	40.8	55	1290
390	369	369	70.3	-	39.8	-	1240
380	360	360	69.8	(110.0)	38.8	52	1205
370	350	350	69.2	-	37.7	-	1170
360	341	341	68.7	(109.0)	36.6	50	1130
350	331	331	68.1	-	35.5	-	1095
340	322	322	67.6	(108.0)	34.4	47	1070
330	313	313	67.0	-	33.3	-	1035
320	303	303	66.4	(107.0)	32.2	45	1005
310	294	294	65.8	-	31.0	-	980
300	284	284	65.2	(105.5)	29.8	42	950
295	280	280	64.8	-	29.2	-	935
290	275	275	64.5	(104.5)	28.5	41	915
285	270	270	64.2	-	27.8	-	905
280	265	265	63.8	(103.5)	27.1	40	890
275	261	261	63.5	-	26.4	-	875
270	256	256	63.1	(102.0)	25.6	38	855
265	252	252	62.7	-	24.8	-	840
260	247	247	62.4	(101.0)	24.0	37	825
255	243	243	62.0	-	23.1	-	805
250	238	238	61.6	99.5	22.2	36	795
245	233	233	61.2	-	21.3	-	780
240	228	228	60.7	98.1	20.3	34	765
230	219	219	-	96.7	(18.0)	33	730
220	209	209	-	95.0	(15.7)	32	695
210	200	200	-	93.4	(13.4)	30	670
200	190	190	-	91.5	(11.0)	29	635
190	181	181	-	89.5	(8.5)	28	605
180	171	171	-	87.1	(6.0)	26	580
170	162	162	-	85.0	(3.0)	25	545
160	152	152	-	81.7	(0.0)	24	515
150	143	143	-	78.7	-	22	490
140	133	133	-	75.0	-	21	455
130	124	124	-	71.2	-	20	425
120	114	114	-	66.7	-	-	390
110	105	105	-	62.3	-	-	-
100	95	95	-	56.2	-	-	-
95	90	90	-	52.0	-	-	-
90	86	86	-	48.0	-	-	-
85	81	81	-	41.0	-	-	-

Extracted from JIS handbook "Iron & steel" (SAE J 417)

Note: 1) 1 MPa = 1 N/mm² - 2) Value in () is not in practical use, but reference only

- 
- **2D to 6D drilling lineup and 4 types of chipbreakers for various machining applications**
 - **High speed and highly efficient machining available with the combination of a CVD outer insert and PVD inner insert**
 - **Highly rigid design with chattering resistance. Excellent hole accuracy**
 - **DRV chamfering attachment**

MagicDrill DRV

Economical inserts with 4 cutting edges

Expanded large toolholder lineup
from \varnothing 40 mm ~ \varnothing 60 mm diameter

MagicDrill DRV with 6D maximum deep-hole drilling



**DRV
KIT OFFER
+20 KYOCERA
INSERTS**

Optimal web thickness reduces chattering with a low cutting force design

Web thickness comparison
(In-house evaluation)

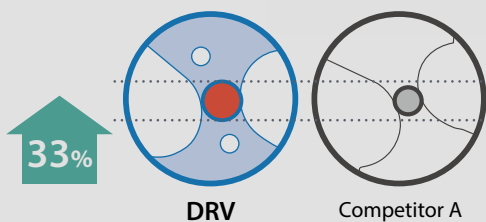

Comparison of cutting diameter variation
(In-house evaluation)

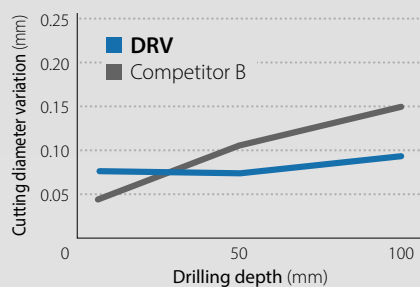

Cutting conditions: $V_c = 150$ m/min, $f = 0.06$ mm/rev
Cutting dia. $\varnothing 20(5D)$, wet, workpiece: S50C

Cutting force comparison
(In-house evaluation)

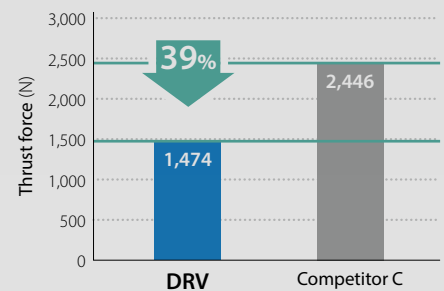

Cutting conditions: $V_c = 200$ m/min, $f = 0.12$ mm/rev
Cutting dia. $\varnothing 20(3D)$, wet, workpiece: S50C

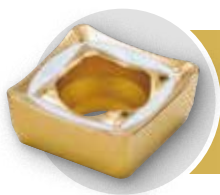

Outer edge

The U-shaped cutting edge generate smooth chip evacuation with compact chips.

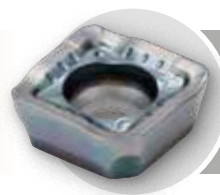

Inner edge

The Spoon-shaped cutting edge generate excellent chip evacuation with 6D maximum deep-hole drilling.

DRV Drill Diameter	2 x Dia. incl. 20 inserts	3 x Dia. incl. 20 inserts	4 x Dia. incl. 20 inserts	5 x Dia. incl. 20 inserts	6 x Dia. incl. 20 inserts
Up to 22.0mm	£215.00	£225.00	£250.00	£265.00	£300.00
23.0mm ~ 26.0mm	£240.00	£255.00	£280.00	£300.00	£345.00
27.0mm ~ 32.0mm	£265.00	£280.00	£310.00	£320.00	£370.00
33.0mm ~ 39.0mm	£310.00	£320.00	£355.00	£375.00	£435.00
40.0mm ~ 49.0mm	£345.00	£355.00	£385.00	£420.00	£485.00
50.0mm ~ 60.0mm	£395.00	£415.00	£440.00	£490.00	£550.00

Note the new drill requires a different inner & outer insert so 20 inserts will have to be purchased with the drill.

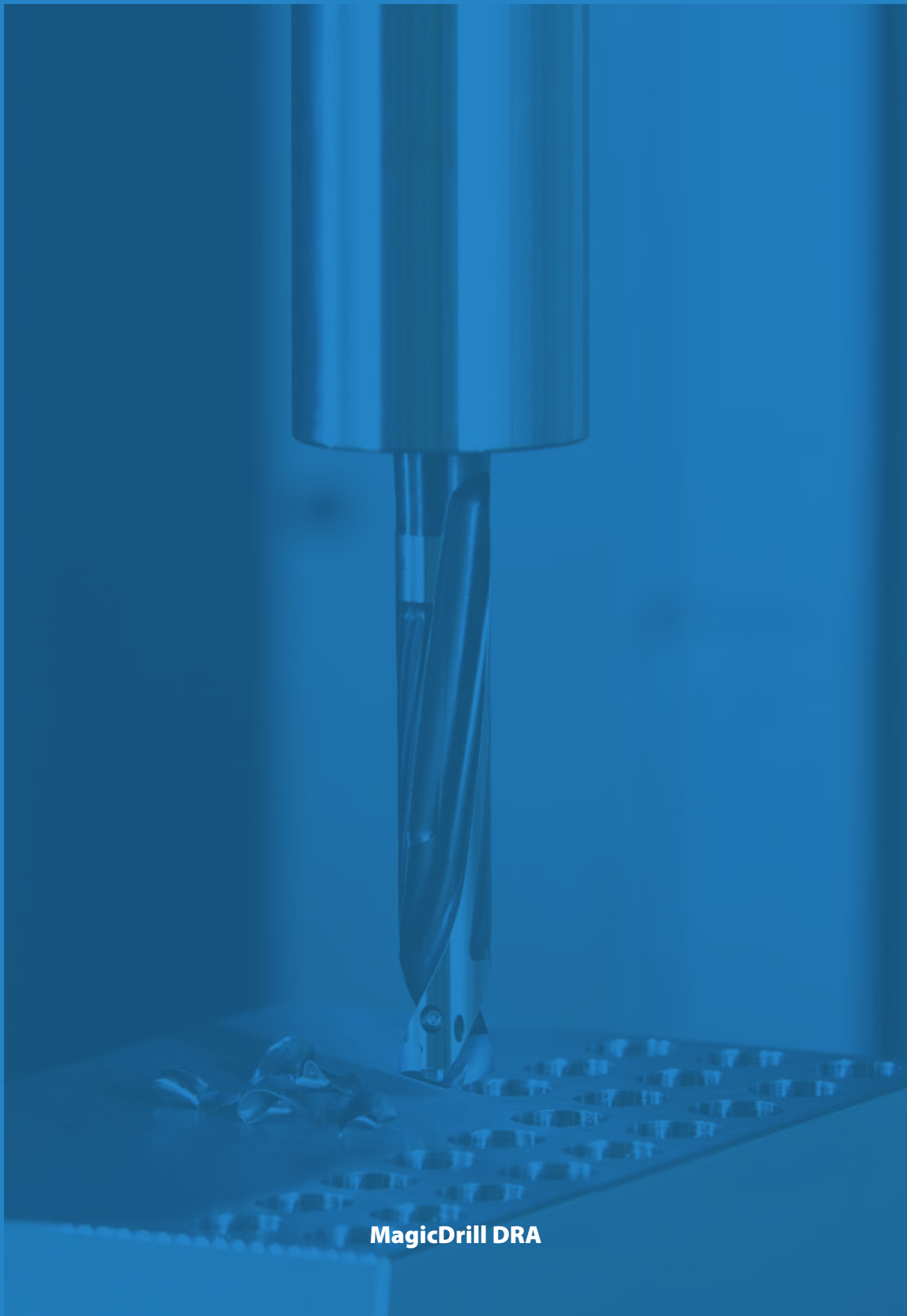

MagicDrill DRA

Excellent hole accuracy with a low cutting force design

New
HQP & HQS
inserts

Now
available in
x3D, x5D & x8D
in toolholder
with flange

MagicDrill DRA

Benefits

- Low cutting force design improves hole accuracy
- Optimal web thickness limits deflection
- Fine chip breaking even in deep hole drilling applications
- Easy insert replacement
- Long tool life and stable machining of various workpieces

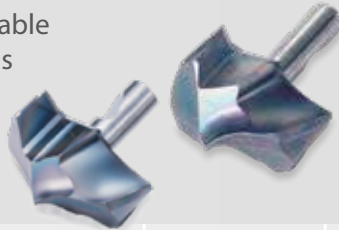

Drilling depth	1.5D	3D	5D	8D	12D
SS-DRA Straight shank	ø7.94 ~ ø25.5				
SF-DRA Flanged shank	ø7.94 ~ ø25.5	ø7.94 ~ ø33			ø12 ~ ø25.5

NEW

Double margin type

High-precision Insert for steel machining

HQP

Special two-step bottom and double margin
Reduces shock for higher-precision machining of steel



Drilling diameter
ø7.94 ~ ø19.9

PR1525

For difficult-to-cut materials/
Stainless steel machining

HQS

Special two-step bottom and double margin
Improving stability of difficult-to-cut materials and stainless steel during machining operations



Drilling diameter
ø8.00 ~ ø19.5



PR1535



MagicDrill DRA



Promotion



Buy 2 inserts at your normal buying discount and receive a corresponding Drill Body at the nett price shown



Drill insert Diameter (mm)	Drill Insert for DRA	Grade for Cast Iron	Grade for Steel and Stainless steel	 Straight shank toolholder	 Flange shank toolholder	Drill length	Drill Promo Price when purchasing 2 inserts
7,94	DA0794M-GM	PR1525	PR1535	SS10-DRA080M-1.5 & 3	SF12-DRA080M-1.5 & 3	1.5+3 × Dia	£90
8,0	DA0800M-GM	PR1525	PR1535	SS10-DRA080M-5	SF12-DRA080M-5	5 × Dia	£105
8,1	DA0810M-GM	PR1525	PR1535	SS10-DRA080M-8	SF12-DRA080M-8	8 × Dia	£125
8,2	DA0820M-GM	PR1525	PR1535				
8,3	DA0830M-GM	PR1525	PR1535				
8,4	DA0840M-GM	PR1525	PR1535				
8,5	DA0850M-GM	PR1525	PR1535	SS10-DRA085M-1.5 & 3	SF12-DRA085M-1.5 & 3	1.5+3 × Dia	£90
8,6	DA0860M-GM	PR1525	PR1535	SS10-DRA085M-5	SF12-DRA085M-5	5 × Dia	£105
8,7	DA0870M-GM	PR1525	PR1535	SS10-DRA085M-8	SF12-DRA085M-8	8 × Dia	£125
8,8	DA0880M-GM	PR1525	PR1535				
8,9	DA0890M-GM	PR1525	PR1535				
9,0	DA0900M-GM	PR1525	PR1535	SS10-DRA090M-1.5 & 3	SF12-DRA090M-1.5 & 3	1.5+3 × Dia	£90
9,1	DA0910M-GM	PR1525	PR1535	SS10-DRA090M-5	SF12-DRA090M-5	5 × Dia	£105
9,2	DA0920M-GM	PR1525	PR1535	SS10-DRA090M-8	SF12-DRA090M-8	8 × Dia	£125
9,3	DA0930M-GM	PR1525	PR1535				
9,4	DA0940M-GM	PR1525	PR1535				
9,5	DA0950M-GM	PR1525	PR1535	SS10-DRA095M-1.5 & 3	SF12-DRA095M-1.5 & 3	1.5+3 × Dia	£90
9,6	DA0960M-GM	PR1525	PR1535	SS10-DRA095M-5	SF12-DRA095M-5	5 × Dia	£105
9,7	DA0970M-GM	PR1525	PR1535	SS10-DRA095M-8	SF12-DRA095M-8	8 × Dia	£125
9,8	DA0980M-GM	PR1525	PR1535				
9,9	DA0990M-GM	PR1525	PR1535				
10,0	DA1000M-GM	PR1525	PR1535	SS12-DRA100M-1.5 & 3	SF16-DRA100M-1.5 & 3	1.5+3 × Dia	£90
10,1	DA1010M-GM	PR1525	PR1535	SS12-DRA100M-5	SF16-DRA100M-5	5 × Dia	£105
10,2	DA1020M-GM	PR1525	PR1535	SS12-DRA100M-8	SF16-DRA100M-8	8 × Dia	£125
10,3	DA1030M-GM	PR1525	PR1535				
10,4	DA1040M-GM	PR1525	PR1535				
10,5	DA1050M-GM	PR1525	PR1535	SS12-DRA105M-1.5 & 3	SF16-DRA105M-1.5 & 3	1.5+3 × Dia	£105
10,6	DA1060M-GM	PR1525	PR1535	SS12-DRA105M-5	SF16-DRA105M-5	5 × Dia	£115
10,7	DA1070M-GM	PR1525	PR1535	SS12-DRA105M-8	SF16-DRA105M-8	8 × Dia	£140
10,8	DA1080M-GM	PR1525	PR1535				

Drill insert Diameter (mm)	Drill Insert for DRA	Grade for Cast Iron	Grade for Steel and Stainless steel	 Straight shank toolholder	 Flange shank toolholder	Drill length	Drill Promo Price when purchasing 2 inserts
10,9	DA1090M-GM	PR1525	PR1535				
11,0	DA1100M-GM	PR1525	PR1535	SS12-DRA110M-1.5 & 3	SF16-DRA110M-1.5 & 3	1.5+3 × Dia	£95
11,1	DA1110M-GM	PR1525	PR1535	SS12-DRA110M-5	SF16-DRA110M-5	5 × Dia	£115
11,2	DA1120M-GM	PR1525	PR1535	SS12-DRA110M-8	SF16-DRA110M-8	8 × Dia	£140
11,3	DA1130M-GM	PR1525	PR1535				
11,4	DA1140M-GM	PR1525	PR1535				
11,5	DA1150M-GM	PR1525	PR1535	SS12-DRA115M-1.5 & 3	SF16-DRA115M-1.5 & 3	1.5+3 × Dia	£95
11,6	DA1160M-GM	PR1525	PR1535	SS12-DRA115M-5	SF16-DRA115M-5	5 × Dia	£115
11,7	DA1170M-GM	PR1525	PR1535	SS12-DRA115M-8	SF16-DRA115M-8	8 × Dia	£125
11,8	DA1180M-GM	PR1525	PR1535				
11,9	DA1190M-GM	PR1525	PR1535				
12,0	DA1200M-GM	PR1525	PR1535	SS14-DRA120M-1.5 & 3	SF16-DRA120M-1.5 & 3	1.5+3 × Dia	£95
12,1	DA1210M-GM	PR1525	PR1535	SS14-DRA120M-5	SF16-DRA120M-5	5 × Dia	£115
12,2	DA1220M-GM	PR1525	PR1535	SS14-DRA120M-8	SF16-DRA120M-8	8 × Dia	£140
12,3	DA1230M-GM	PR1525	PR1535		SF16-DRA120M-12	12 × Dia	£155
12,4	DA1240M-GM	PR1525	PR1535				
12,5	DA1250M-GM	PR1525	PR1535	SS14-DRA125M-1.5 & 3	SF16-DRA125M-1.5 & 3	1.5+3 × Dia	£95
12,6	DA1260M-GM	PR1525	PR1535	SS14-DRA125M-5	SF16-DRA125M-5	5 × Dia	£115
12,7	DA1270M-GM	PR1525	PR1535	SS14-DRA125M-8	SF16-DRA125M-8	8 × Dia	£140
12,8	DA1280M-GM	PR1525	PR1535		SF16-DRA125M-12	12 × Dia	£155
12,9	DA1290M-GM	PR1525	PR1535				
13,0	DA1300M-GM	PR1525	PR1535	SS14-DRA130M-1.5 & 3	SF16-DRA130M-1.5 & 3	1.5+3 × Dia	£95
13,1	DA1310M-GM	PR1525	PR1535	SS14-DRA130M-5	SF16-DRA130M-5	5 × Dia	£115
13,2	DA1320M-GM	PR1525	PR1535	SS14-DRA130M-8	SF16-DRA130M-8	8 × Dia	£135
13,3	DA1330M-GM	PR1525	PR1535		SF16-DRA130M-12	12 × Dia	£155
13,4	DA1340M-GM	PR1525	PR1535				
13,5	DA1350M-GM	PR1525	PR1535	SS14-DRA135M-1.5 & 3	SF16-DRA135M-1.5 & 3	1.5+3 × Dia	£95
13,6	DA1360M-GM	PR1525	PR1535	SS14-DRA135M-5	SF16-DRA135M-5	5 × Dia	£115
13,7	DA1370M-GM	PR1525	PR1535	SS14-DRA135M-8	SF16-DRA135M-8	8 × Dia	£135
13,8	DA1380M-GM	PR1525	PR1535		SF16-DRA135M-12	12 × Dia	£155
13,9	DA1390M-GM	PR1525	PR1535				
14,0	DA1400M-GM	PR1525	PR1535	SS16-DRA140M-1.5 & 3	SF16-DRA140M-1.5 & 3	1.5+3 × Dia	£95
14,1	DA1410M-GM	PR1525	PR1535	SS16-DRA140M-5	SF16-DRA140M-5	5 × Dia	£115
14,2	DA1420M-GM	PR1525	PR1535	SS16-DRA140M-8	SF16-DRA140M-8	8 × Dia	£135
14,3	DA1430M-GM	PR1525	PR1535		SF16-DRA140M-12	12 × Dia	£155
14,4	DA1440M-GM	PR1525	PR1535				
14,5	DA1450M-GM	PR1525	PR1535	SS16-DRA145M-1.5 & 3	SF16-DRA145M-1.5 & 3	1.5+3 × Dia	£95
14,6	DA1460M-GM	PR1525	PR1535	SS16-DRA145M-5	SF16-DRA145M-5	5 × Dia	£115
14,7	DA1470M-GM	PR1525	PR1535	SS16-DRA145M-8	SF16-DRA145M-8	8 × Dia	£135
14,8	DA1480M-GM	PR1525	PR1535		SF16-DRA145M-12	12 × Dia	£155
14,9	DA1490M-GM	PR1525	PR1535				
15,0	DA1500M-GM	PR1525	PR1535	SS16-DRA150M-1.5 & 3	SF20-DRA150M-1.5 & 3	1.5+3 × Dia	£100
15,1	DA1510M-GM	PR1525	PR1535	SS16-DRA150M-5	SF20-DRA150M-5	5 × Dia	£120
15,2	DA1520M-GM	PR1525	PR1535	SS16-DRA150M-8	SF20-DRA150M-8	8 × Dia	£150
15,3	DA1530M-GM	PR1525	PR1535		SF25-DRA150M-12	12 × Dia	£155
15,4	DA1540M-GM	PR1525	PR1535				
15,5	DA1550M-GM	PR1525	PR1535				

Drill insert Diameter (mm)	Drill Insert for DRA	Grade for Cast Iron	Grade for Steel and Stainless steel	 Straight shank toolholder	 Flange shank toolholder	Drill length	Drill Promo Price when purchasing 2 inserts
15,6	DA1560M-GM	PR1525	PR1535				
15,7	DA1570M-GM	PR1525	PR1535				
15,8	DA1580M-GM	PR1525	PR1535				
15,9	DA1590M-GM	PR1525	PR1535				
16,0	DA1600M-GM	PR1525	PR1535	SS18-DRA160M-1.5 & 3	SF20-DRA160M-1.5 & 3	1.5+3 × Dia	£100
16,1	DA1610M-GM	PR1525	PR1535	SS18-DRA160M-5	SF20-DRA160M-5	5 × Dia	£120
16,2	DA1620M-GM	PR1525	PR1535	SS18-DRA160M-8	SF20-DRA160M-8	8 × Dia	£150
16,3	DA1630M-GM	PR1525	PR1535		SF25-DRA160M-12	12 × Dia	£160
16,4	DA1640M-GM	PR1525	PR1535				
16,5	DA1650M-GM	PR1525	PR1535				
16,6	DA1660M-GM	PR1525	PR1535				
16,7	DA1670M-GM	PR1525	PR1535				
16,8	DA1680M-GM	PR1525	PR1535				
16,9	DA1690M-GM	PR1525	PR1535				
17,0	DA1700M-GM	PR1525	PR1535	SS18-DRA170M-1.5 & 3	SF20-DRA170M-1.5 & 3	1.5+3 × Dia	£100
17,2	DA1720M-GM	PR1525	PR1535	SS18-DRA170M-5	SF20-DRA170M-5	5 × Dia	£120
17,3	DA1730M-GM	PR1525	PR1535	SS18-DRA170M-8	SF20-DRA170M-8	8 × Dia	£150
17,4	DA1740M-GM	PR1525	PR1535		SF25-DRA170M-12	12 × Dia	£170
17,5	DA1750M-GM	PR1525	PR1535				
17,6	DA1760M-GM	PR1525	PR1535				
17,7	DA1770M-GM	PR1525	PR1535				
17,8	DA1780M-GM	PR1525	PR1535				
17,9	DA1790M-GM	PR1525	PR1535				
18,0	DA1800M-GM	PR1525	PR1535	SS20-DRA180M-1.5 & 3	SF25-DRA180M-1.5 & 3	1.5+3 × Dia	£120
18,1	DA1810M-GM	PR1525	PR1535	SS20-DRA180M-5	SF25-DRA180M-5	5 × Dia	£145
18,2	DA1820M-GM	PR1525	PR1535	SS20-DRA180M-8	SF25-DRA180M-8	8 × Dia	£170
18,3	DA1830M-GM	PR1525	PR1535		SF25-DRA180M-12	12 × Dia	£185
18,4	DA1840M-GM	PR1525	PR1535				
18,5	DA1850M-GM	PR1525	PR1535				
18,6	DA1860M-GM	PR1525	PR1535				
18,7	DA1870M-GM	PR1525	PR1535				
18,8	DA1880M-GM	PR1525	PR1535				
18,9	DA1890M-GM	PR1525	PR1535				
19,0	DA1900M-GM	PR1525	PR1535	SS20-DRA190M-1.5 & 3	SF25-DRA190M-1.5 & 3	1.5+3 × Dia	£120
19,1	DA1910M-GM	PR1525	PR1535	SS20-DRA190M-5	SF25-DRA190M-5	5 × Dia	£145
19,2	DA1920M-GM	PR1525	PR1535	SS20-DRA190M-8	SF25-DRA190M-8	8 × Dia	£185
19,3	DA1930M-GM	PR1525	PR1535		SF25-DRA190M-12	12 × Dia	£195
19,4	DA1940M-GM	PR1525	PR1535				
19,5	DA1950M-GM	PR1525	PR1535				
19,6	DA1960M-GM	PR1525	PR1535				
19,7	DA1970M-GM	PR1525	PR1535				
19,8	DA1980M-GM	PR1525	PR1535				
19,9	DA1990M-GM	PR1525	PR1535				
20,0	DA2000M-GM	PR1525	PR1535	SS25-DRA200M-1.5 & 3	SF25-DRA200M-1.5 & 3	1.5+3 × Dia	£145
20,1	DA2010M-GM	PR1525	PR1535	SS25-DRA200M-5	SF25-DRA200M-5	5 × Dia	£170
20,2	DA2020M-GM	PR1525	PR1535	SS25-DRA200M-8	SF25-DRA200M-8	8 × Dia	£205
20,3	DA2030M-GM	PR1525	PR1535		SF25-DRA200M-12	12 × Dia	£220

Drill insert Diameter (mm)	Drill Insert for DRA	Grade for Cast Iron	Grade for Steel and Stainless steel	 Straight shank toolholder	 Flange shank toolholder	Drill length	Drill Promo Price when purchasing 2 inserts
20,4	DA2040M-GM	PR1525	PR1535				
20,5	DA2050M-GM	PR1525	PR1535				
20,6	DA2060M-GM	PR1525	PR1535				
20,7	DA2070M-GM	PR1525	PR1535				
20,8	DA2080M-GM	PR1525	PR1535				
20,9	DA2090M-GM	PR1525	PR1535				
21,0	DA2100M-GM	PR1525	PR1535	SS25-DRA210M-1.5 & 3	SF25-DRA210M-1.5 & 3	1.5+3 × Dia	£145
21,5	DA2150M-GM	PR1525	PR1535	SS25-DRA210M-5	SF25-DRA210M-5	5 × Dia	£170
				SS25-DRA210M-8	SF25-DRA210M-8	8 × Dia	£205
					SF25-DRA210M-12	12 × Dia	£220
22,0	DA2200M-GM	PR1525	PR1535	SS25-DRA220M-1.5 & 3	SF25-DRA220M-1.5 & 3	1.5+3 × Dia	£145
22,5	DA2250M-GM	PR1525	PR1535	SS25-DRA220M-5	SF25-DRA220M-5	5 × Dia	£170
				SS25-DRA220M-8	SF25-DRA220M-8	8 × Dia	£205
					SF25-DRA220M-12	12 × Dia	£230
23,0	DA2300M-GM	PR1525	PR1535	SS25-DRA230M-1.5 & 3	SF25-DRA230M-1.5 & 3	1.5+3 × Dia	£155
23,5	DA2350M-GM	PR1525	PR1535	SS25-DRA230M-5	SF25-DRA230M-5	5 × Dia	£180
				SS25-DRA230M-8	SF25-DRA230M-8	8 × Dia	£220
					SF25-DRA230M-12	12 × Dia	£245
24,0	DA2400M-GM	PR1525	PR1535	SS25-DRA240M-1.5 & 3	SF25-DRA240M-1.5 & 3	1.5+3 × Dia	£155
24,5	DA2450M-GM	PR1525	PR1535	SS25-DRA240M-5	SF25-DRA240M-5	5 × Dia	£180
				SS25-DRA240M-8	SF25-DRA240M-8	8 × Dia	£220
					SF25-DRA240M-12	12 × Dia	£245
25,0	DA2500M-GM	PR1525	PR1535	SS32-DRA250M-1.5 & 3	SF25-DRA250M-1.5 & 3	1.5+3 × Dia	£155
25,5	DA2550M-GM	PR1525	PR1535	SS32-DRA250M-5	SF25-DRA250M-5	5 × Dia	£180
				SS32-DRA250M-8	SF25-DRA250M-8	8 × Dia	£230
					SF25-DRA250M-12	12 × Dia	£275
26,0	DA2600M-GM	PR1525	PR1535		SF32-DRA260M-3	3 × Dia	£250
26,0	DA2600M-GM	PR1525	PR1535		SF32-DRA260M-5	5 × Dia	£300
26,0	DA2600M-GM	PR1525	PR1535		SF32-DRA260M-8	8 × Dia	£360
27,0	DA2700M-GM	PR1525	PR1535		SF32-DRA270M-3	3 × Dia	£250
27,0	DA2700M-GM	PR1525	PR1535		SF32-DRA270M-5	5 × Dia	£300
27,0	DA2700M-GM	PR1525	PR1535		SF32-DRA270M-8	8 × Dia	£360
28,0	DA2800M-GM	PR1525	PR1535		SF32-DRA280M-3	3 × Dia	£250
28,0	DA2800M-GM	PR1525	PR1535		SF32-DRA280M-5	5 × Dia	£300
28,0	DA2800M-GM	PR1525	PR1535		SF32-DRA280M-8	8 × Dia	£360
29,0	DA2900M-GM	PR1525	PR1535		SF32-DRA290M-3	3 × Dia	£315
29,0	DA2900M-GM	PR1525	PR1535		SF32-DRA290M-5	5 × Dia	£350
29,0	DA2900M-GM	PR1525	PR1535		SF32-DRA290M-8	8 × Dia	£400
30,0	DA3000M-GM	PR1525	PR1535		SF32-DRA300M-3	3 × Dia	£315
30,0	DA3000M-GM	PR1525	PR1535		SF32-DRA300M-5	5 × Dia	£350
30,0	DA3000M-GM	PR1525	PR1535		SF32-DRA300M-8	8 × Dia	£400
31,0	DA3100M-GM	PR1525	PR1535		SF32-DRA310M-3	3 × Dia	£315
31,0	DA3100M-GM	PR1525	PR1535		SF32-DRA310M-5	5 × Dia	£350
31,0	DA3100M-GM	PR1525	PR1535		SF32-DRA310M-8	8 × Dia	£400
32,0	DA3200M-GM	PR1525	PR1535		SF32-DRA320M-3	3 × Dia	£315
32,0	DA3200M-GM	PR1525	PR1535		SF32-DRA320M-5	5 × Dia	£350
32,0	DA3200M-GM	PR1525	PR1535		SF32-DRA320M-8	8 × Dia	£400

NEW

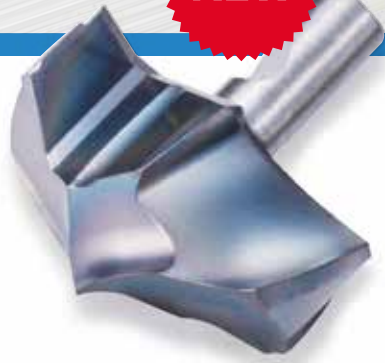

HQP

High-precision Insert for Steel Machining

Improved centripetal force with special two-step bottom and double margin design
Excellent cylindricity, roundness and surface finish in steel machining

Improved Centripetal Forces Delivers High-precision Machining Capabilities for both Machining Centers and Lathes

Special two-step bottom, large rake angle and double margin design reduce initial shock for higher-precision machining

Cutting force comparison when entering the workpiece (Internal evaluation)

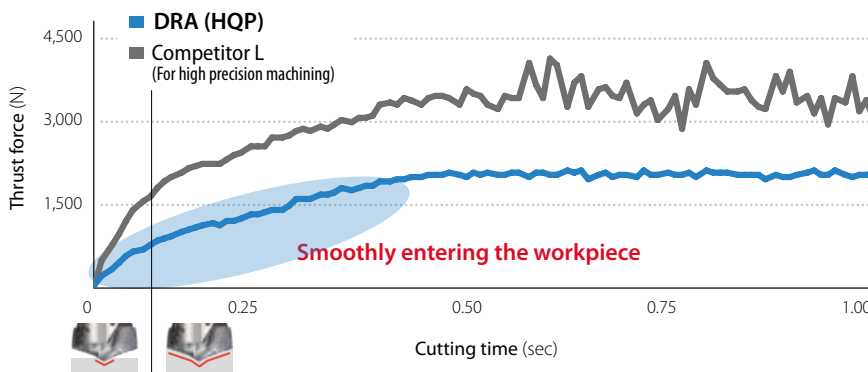

Cutting Conditions: $V_c = 100$ m/min, $f = 0.25$ mm/rev, $H = 30$ mm, Wet Workpiece: S50C $\phi 16$ (3D)

Special Two-step Bottom



Large Rake Angle



Double Margin

Cylindricity and roundness comparison (Internal evaluation)

Machining Center (BT50)

DRA (HQP)



Cylindricity: $19 \mu\text{m}$
Roundness: $17 \mu\text{m}$ (70 mm)

Cutting Conditions: $V_c = 100$ m/min, $f = 0.25$ mm/rev, $H = 80$ mm, Wet Workpiece: S50C $\phi 16$ (5D)

Competitor M (For high precision machining)

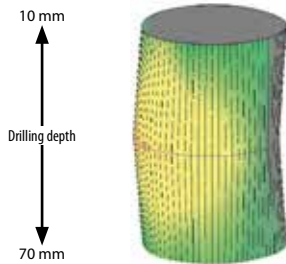

Cylindricity: $52 \mu\text{m}$
Roundness: $19 \mu\text{m}$ (70 mm)

Lathes

DRA (HQP)

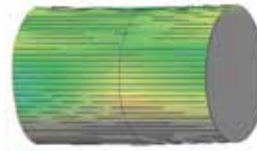

Cylindricity: $19 \mu\text{m}$
Roundness: $9 \mu\text{m}$ (60 mm)

Cutting Conditions: $V_c = 120$ m/min, $f = 0.3$ mm/rev, $H = 65$ mm, Wet Workpiece: SCM435 $\phi 13$ (5D)

Competitor N (For high precision machining)

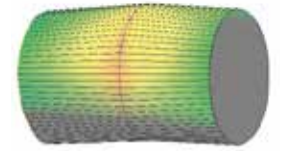

Cylindricity: $71 \mu\text{m}$
Roundness: $12 \mu\text{m}$ (60 mm)

Excellent Surface Finish with Unique Flute Shape

Controlled chips reduce scratches on the hole wall

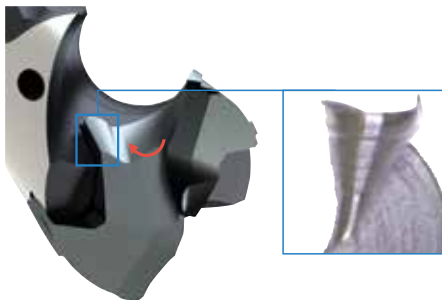

Hole wall surface finish comparison (Internal evaluation)

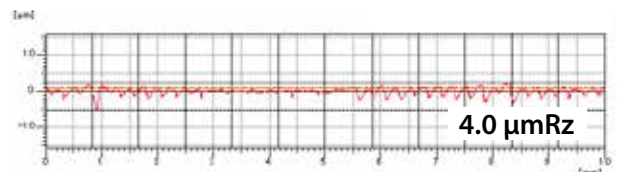

Cutting Conditions: $V_c = 100$ m/min, $f = 0.25$ mm/rev, $H = 80$ mm, Wet Workpiece: S50C $\phi 16$ (5D)

NEW



HQS

Difficult-to-cut Materials/Stainless Steel Machining

Original design suitable for machining of difficult-to-cut materials such as Inconel High quality and stable machining provide long tool life

Three features specializing in difficult-to-cut materials machining

Special Two-step Bottom



Suppress sudden fracture when entering the workpiece
Improvement of cutting edge strength

Double Margin

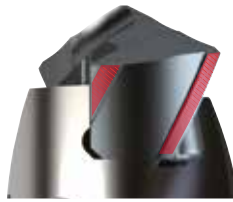

Optimized for difficult-to-cut materials machining
Improvement of heat resistance

Unique Flute Shape



Superior chip control
Prevents damage to hole walls. Excellent finished surface

Long tool life and high-quality machining of Inconel and stainless steel

Inconel

The shoulder part and chisel part of competitor were fractured and the tool life was shortened. HQS maintains long tool life

Wear Resistance Comparison (Internal evaluation)

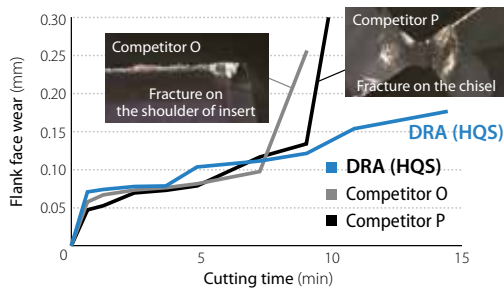

DRA (HQS)

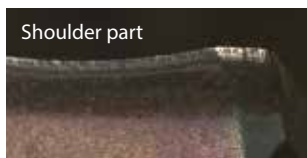

Normal wear condition

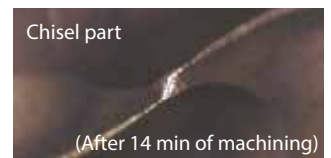

Good without fracture

Cutting Conditions: $V_c = 20$ m/min, $f = 0.15$ mm/rev, Drilling Diameter $\phi 14.5$ (3D). Drilling Depth 40 mm, Wet (internal/external), Workpiece: Inconel 718, BT50 M/C

Stainless Steel

HQS has excellent centripetal properties with special two-step bottom and double margin. Provides superior hole diameter accuracy

Hole Diameter Accuracy Comparison (Internal evaluation)

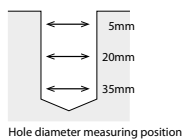
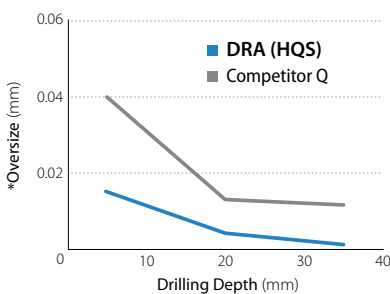

After machining



Good



Rifling occurred

Cutting Conditions: $V_c = 40$ m/min, $f = 0.10$ mm/rev, Drilling Diameter $\phi 10.8$ (5D). Drilling Depth 40 mm, Wet (internal/external), Workpiece: SUS304, BT50 M/C

*Oversize is the difference between the actual hole diameter and the drill diameter



PX turning insert offer



Increase your Productivity!

Increase your machine shops capacity

Implement the new Kyocera Low Power, High Feed Rate PX turning inserts for Steel machining

- Low cutting force by curved cutting edge design
- Prevents crater wear by positive land on insert corner
- Prevents adhesion by 2-steps dot chip deflector

MINIMUM
25%
INCREASE



PX turning insert offer

Implement the new Kyocera Low Power, High Feed Rate PX turning inserts for STEEL machining - and increase your productivity by at least 25%.



2-step dots

Chip breaking while preventing adhesion.

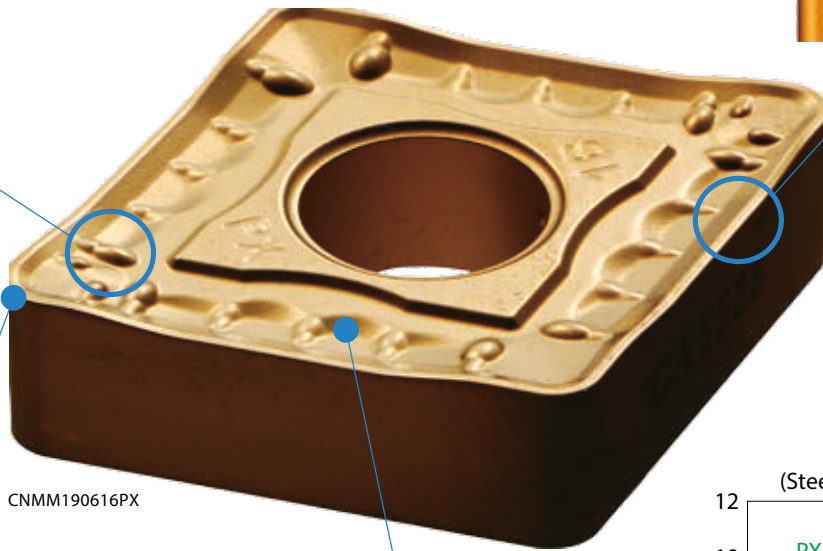

CNMM190616PX



Curved edge

Cutting force reduction at large ap.

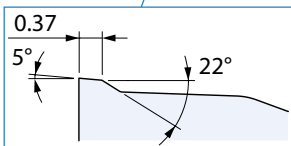

Positive corner land

Cutting force reduction at the point of first contact and controls crater wear.

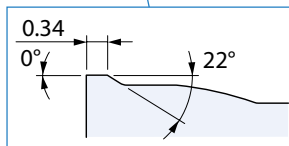

Wide land and large rake angle

Good balance of sharpness and cutting edge strength.

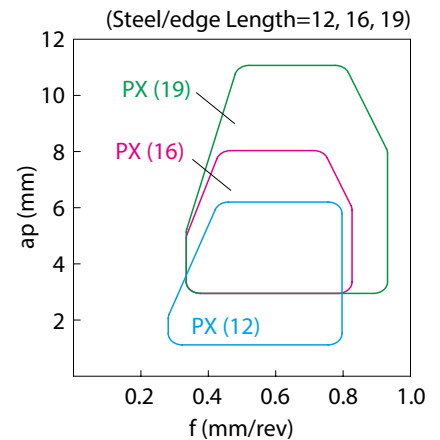

Reduce your manufacturing costs

For the majority of production enterprises, productivity can be increased, quality improved and unit costs can be reduced by utilising optimum tooling technology and using it correctly. Looking at the typical cost structure in a manufacturing company reveals that tool costs make up only a small part of the total costs of manufacturing any given component.

Even though the cutting tool costs make up only a minor part of total costs, the fact is that changes in the tooling setup can have a major effect on the fixed costs.

i.e. if you increase the cutting data through cutting tool improvements you decrease the fixed costs per component.

Fixed costs

Buildings and associated overheads	22%
Labour and associated employment costs	31%
Machine tool costs.	27%

Variable costs

Work piece material	17%
Cutting tool cost	3%

Insert Ref	Continuous Cutting CA115P	Large Depth or Interrupted Cut CA125P	Nett. Price
CNMM120408PX	●	●	£3.80
CNMM120412PX	●	●	£3.80
CNMM120416PX	●	●	£3.80
CNMM160608PX	●	●	£6.00
CNMM160612PX	●	●	£6.00
CNMM160616PX	●	●	£6.00
CNMM190608PX	●	●	£8.48
CNMM190612PX	●	●	£8.48
CNMM190616PX	●	●	£8.48
CNMM190624PX	●	●	£8.48
DNMM150408PX	N/A	●	£3.88
DNMM150412PX	N/A	●	£3.88
DNMM150416PX	N/A	●	£3.88
DNMM150608PX	●	●	£5.15
DNMM150612PX	●	●	£5.15
DNMM150616PX	N/A	●	£5.15

Insert Ref	Continuous Cutting CA115P	Large Depth or Interrupted Cut CA125P	Nett. Price
SNMM120408PX	●	●	£3.60
SNMM120412PX	●	●	£3.60
SNMM120416PX	N/A	●	£3.60
SNMM150612PX	N/A	●	£5.70
SNMM150616PX	N/A	●	£5.70
SNMM190612PX	●	●	£8.00
SNMM190616PX	●	●	£8.00
SNMM190624PX	N/A	●	£8.00
TNMM160408PX	N/A	●	£3.00
TNMM160412PX	N/A	●	£3.00
TNMM220408PX	N/A	●	£3.65
TNMM220412PX	N/A	●	£3.65
TNMM220416PX	N/A	●	£3.65

LET US
HELP YOU
REDUCING YOUR
COSTS BY AT LEAST
25%

Example

If the total manufacturing cost of a component is £10.00, the tooling cost is £0.30/component.

If you were to reduce the cost of tooling by 33% (£0.20/component), you would only reduce the cost per part to £9.90 (or 1%)

If you were to find an alternative cutting tool that gave a 50% increase in tool life (£0.20/component), you would only reduce the cost per part to £9.90 (or 1%)

Alternatively, if you were to increase the cutting data by 20%, even if this meant a 50% increase in cutting tool cost to £0.45/component, you would reduce your actual cost per part by 15% to £8.55.

Kyocera Unimerco's aim is to reduce your manufacturing costs by at least 25% on every component we are invited to analyse.

KIT OFFER
10 INSERTS
 (COATED OR UNCOATED)
1 PART-OFF
BLADE

High Performance at an extremely low cost

Cut-off process can be a problematic process, requiring a trouble-free reliable solution. The KPK Series features new insert, blade, and tool block designs for rigid, safe, and secure cut-off operations.



Workpiece	Cutting speed Vc (m/min)		
	MEGACOAT NANO		Carbide
	PR1625	PR1535	GW15
Carbon steel	80-220 ★	80-220 ☆	-
Alloy steel	70-200 ★	70-200 ☆	-
Stainless steel	60-150 ☆	60-150 ★	-
Cast iron	-	-	50-100 ★
Aluminum alloy	-	-	200-450 ★
Brass	-	-	100-200 ★



★ 1st recommendation ☆ 2nd recommendation

Blade Height	2mm Insert Width (PKM)	3mm Insert Width (PKM)	4mm Insert Width (PKM)	5mm Insert Width (PKM)
26mm Standard (KPKB)	£78.00	£78.00	£88.00	£88.00
32mm Standard (KPKB)	£82.00	£82.00	£92.00	£92.00
Add a Block ~ Standard (KTKTB) £125.00 or Thro Coolant (KPKTB-JCT) £165.00				
26mm Thro Coolant (KPKB -JCT)	£98.00	£98.00	£108.00	£108.00
32mm Thro Coolant (KPKB -JCT)	£102.00	£102.00	£112.00	£112.00

Inserts available in 3 Carbide Grades, 4 Widths, Neutral or Angled Chipbreaker PM ~ General Purpose Chipbreaker PH ~ Heavy Duty



Blade dimensions

Description	Availability	Cutting dia.	Dimensions (mm)						Edge width (mm)	Drawing	Parts Insert wrench	Applicable inserts	Applicable toolholder block		
			CUTDIA	*H	HF	B	LF	A						CW	
KPKB 19-1	●	32	19	15.7	2.6	86	1.4	1.6	Fig.1	LPW-5	PKM16...	KTKTB \bigcirc -19			
	●	40							1.8				2.0	2.4	Fig.2
KPKB 26-1	●	35	26	21.4	2.6	110	1.4	1.6	Fig.1		PKM16...	KPKTB \bigcirc -26JCT KTKTB \bigcirc -26			
	●	50							1.8				2.0	2.4	Fig.2
	●	75							2.6				3.0		
	●	80							3.4				4.0		
	●	80							4.2				4.8	5.0	
KPKB 32-1	●	35	32	25.0	2.6	150	1.4	1.6	Fig.1		PKM16...	KPKTB \bigcirc -32JCT KTKTB \bigcirc -32 KTKTBF \bigcirc -32			
	●	50							1.8				2.0	2.4	Fig.2
	●	100							2.6				3.0		
	●	100							3.4				4.0		
	●	120							4.2				4.8	5.0	
	●	120							5.4	6.0					

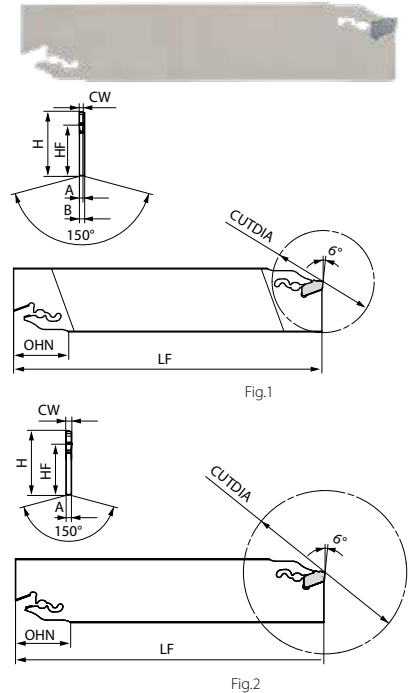

● : Availability

	Shape Right-hand shown	Description	Dimensions (mm)		Angle	MEGACOAT NANO		Carbide	
			CW	RE		PR1625	PR1535	GW15	
Without lead angle	General use	PKM 16N-01SPM	1.6	0.15	-	●	●	●	●
		20N-020PM	2.0	0.20		●	●	●	●
		24N-020PM	2.4	0.20		●	●	●	●
		30N-025PM	3.0	0.25		●	●	●	●
		40N-030PM	4.0	0.30		●	●	●	●
		48N-030PM	4.8	0.30		●	●	●	●
		50N-030PM	5.0	0.30		●	●	●	●
		60N-035PM	6.0	0.35		●	●	●	●
	Tough edge	PKM 20N-020PH	2.0	0.20		●	●	●	●
		30N-030PH	3.0	0.30		●	●	●	●
		40N-030PH	4.0	0.30		●	●	●	●
		50N-030PH	5.0	0.30		●	●	●	●
		60N-040PH	6.0	0.40		●	●	●	●
								●	●
With lead angle	PSIR \angle	PKM 16 $\frac{R}{L}$ -015PM-6D	1.6	0.15	6°	●	●	●	●
		20 $\frac{R}{L}$ -020PM-6D	2.0	0.20		●	●	●	●
		24 $\frac{R}{L}$ -020PM-6D	2.4	0.20		●	●	●	●
		30 $\frac{R}{L}$ -025PM-6D	3.0	0.25		●	●	●	●
		40 $\frac{R}{L}$ -030PM-6D	4.0	0.30		●	●	●	●
		50 $\frac{R}{L}$ -030PM-6D	5.0	0.30		●	●	●	●

● : Available

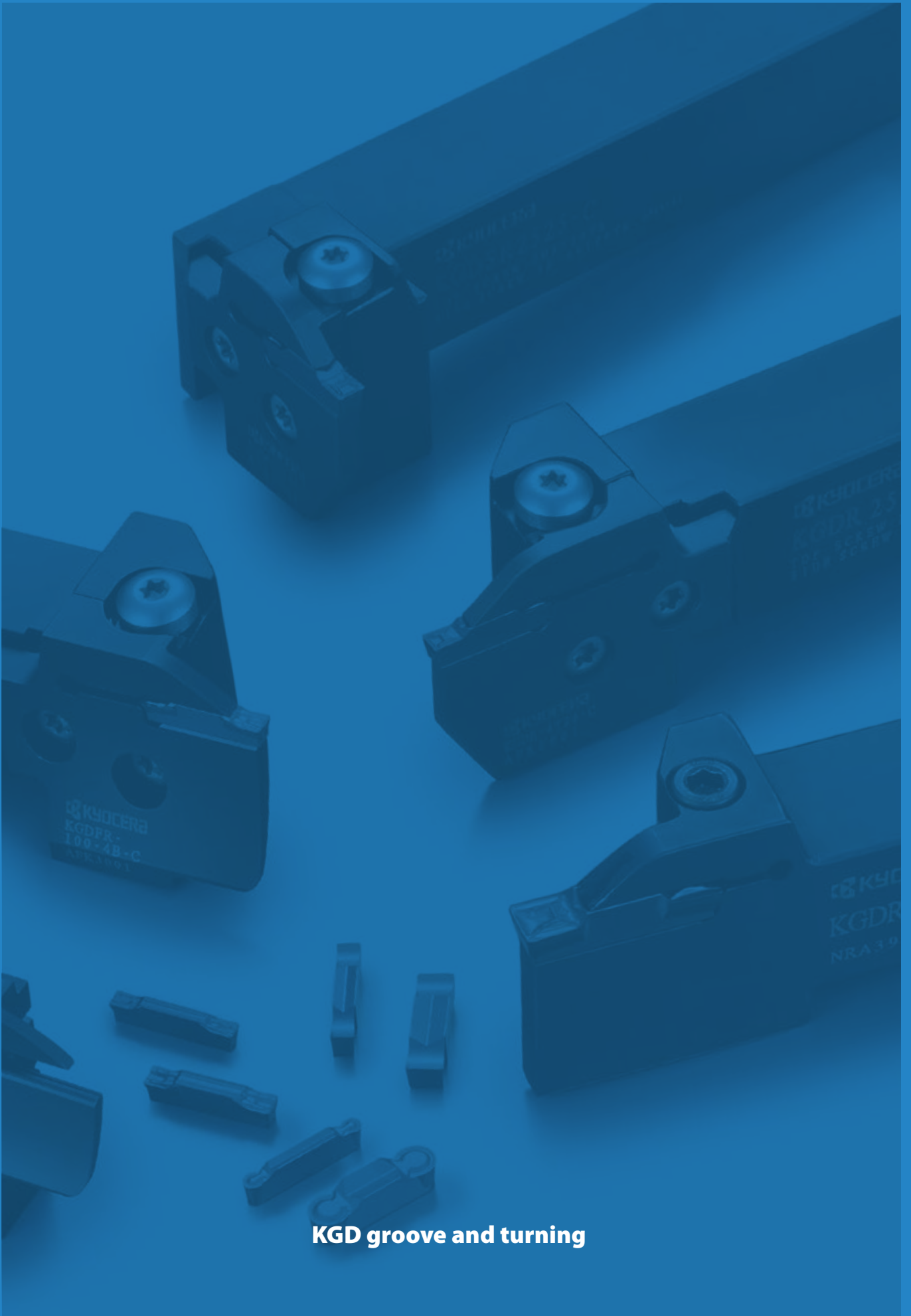

KGD groove and turning

KGD groove and turning system

**1 KGD
EXTERNAL TOOLHOLDER
+ 10 INSERTS
COATED DOUBLE ENDED
(20 EDGES)**



**High Performance
Low Insert Cost**

(Up to 50% lower than the leading brands)

Flat insert

		Offer price
Kit 1 2.4 mm	1 x KGDR/L2020K-2.4T17 10 x GDM2420N-020GM PR1225	£148.00
Kit 2 3.0 mm	1 x KGDR/L2020K-3T20 10 x GDM3020N-040GM PR1225	£148.00
Kit 3 3.0 mm	1 x KGDR/L2525M-3T20 10 x GDM3020N-040GM PR1225	£160.00
Kit 4 4.0 mm	1 x KGDR/L2525M-4T25 10 x GDM4020N-040GM PR1225	£160.00
Kit 5 5.0 mm	1 x KGDR/L2525M-5T25 10 x GDM5020N-040GM PR1225	£165.00
Kit 6 6.0 mm	1 x KGDR/L2525M-6T30 10 x GDM6020N-040GM PR1225	£185.00
Kit 7 8.0 mm	1 x KGDR/L3232P-8T25 10 x GDM8030N-080GM PR1225	£220.00

Full radius insert

		Offer price
Kit 8 3.0 mm	1 x KGDR/L2020K-3T20 10 x GDM3020N-150R-CM PR1225	£150.00
Kit 9 3.0 mm	1 x KGDR/L2525M-3T20 10 x GDM3020N-150R-CM PR1225	£165.00
Kit 10 4.0 mm	1 x KGDR/L2525M-4T25 10 x GDM4020N-200R-CM PR1225	£165.00
Kit 11 5.0 mm	1 x KGDR/L2525M-5T25 10 x GDM5020N-250R-CM PR1225	£175.00
Kit 12 6.0 mm	1 x KGDR/L2525M-6T30 10 x GDM6020N-300R-CM PR1225	£195.00

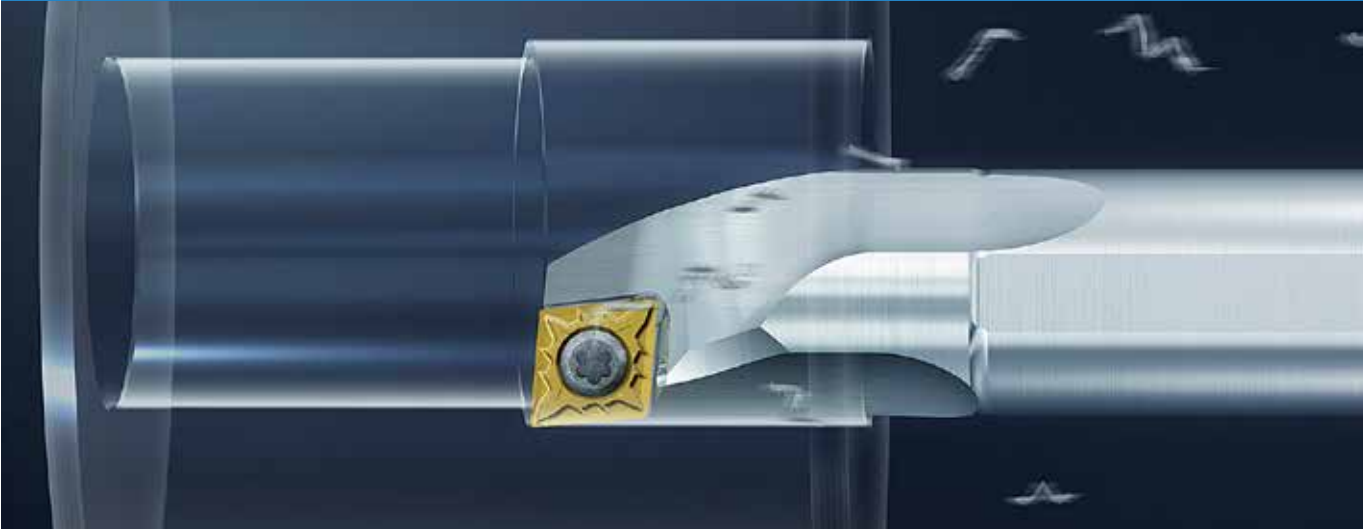

Dynamic Boring Bar offer

STREAMLINED HEAD DRIVEN BY THE LATEST COMPUTER SIMULATION TECHNOLOGY

Tool holder design through stress analysis

Maximum structural thickness for high tool holder rigidity. Controls chattering to achieve stable machining.

Large chip pocket

Exhibits superior chip evacuation.

- Strength of a Steel bar with Anti-vibration properties close to that of Solid Carbide
- Better Swarf control and Surface Finish

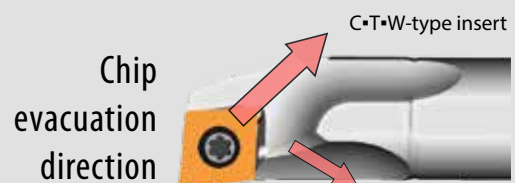

The Dynamic Bar achieves superior chip evacuation

High rigidity and chattering resistance are ensured by using a special alloy and with help of stress analysis technology. Previously unattained surface finish and dimensional accuracy are now achieved.



Comparison of vibration tendency

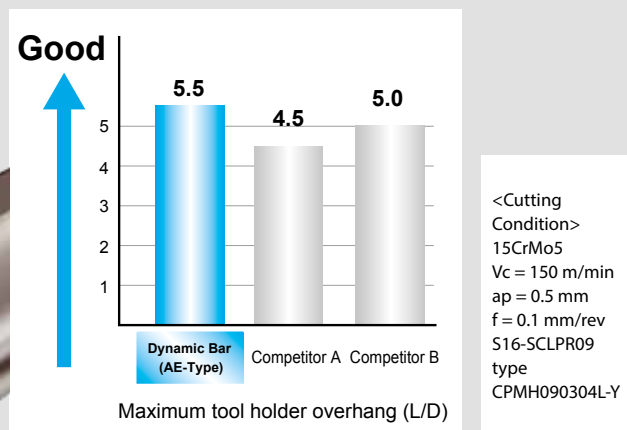

Comparison of surface finish

Vibration of the Dynamic Bar was minimal even at high cutting speeds, enabling stable machining.

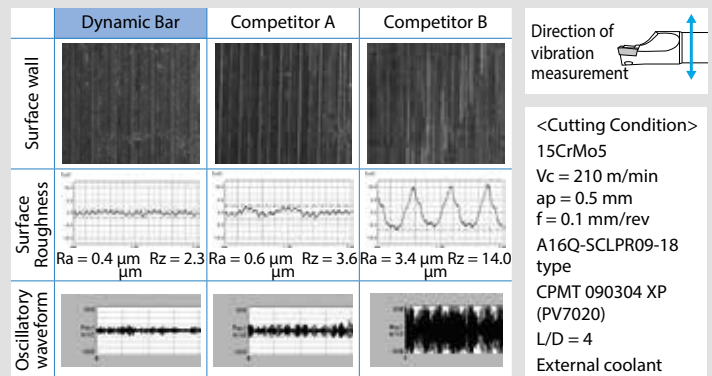

Set 1 - RH CA515 Steel

1 pcs. A08X SCLCR 06-10AE	10 pcs.	£215
1 pcs. A10L SCLCR 06-12AE	CCMT 060204 HQ CA515	
1 pcs. A12M SCLCR 06-14AE		

Set 1 - LH CA515 Steel

1 pcs. A08X SCLCL 06-10AE	10 pcs.	£215
1 pcs. A10L SCLCL 06-12AE	CCMT 060204 HQ CA515	
1 pcs. A12M SCLCL 06-14AE		

Set 1 - RH CA6525 Stainless

1 pcs. A08X SCLCR 06-10AE	10 pcs.	£215
1 pcs. A10L SCLCR 06-12AE	CCMT 060204 HQ CA6525	
1 pcs. A12M SCLCR 06-14AE		

Set 1 - LH CA6525 Stainless

1 pcs. A08X SCLCL 06-10AE	10 pcs.	£215
1 pcs. A10L SCLCL 06-12AE	CCMT 060204 HQ CA6525	
1 pcs. A12M SCLCL 06-14AE		

Set 2 - RH CA515 Steel

1 pcs. A16Q SCLCR 09-18AE	10 pcs.	£270
1 pcs. A20R SCLCR 09-22AE	CCMT 09T304 HQ CA515	
1 pcs. A25S SCLCR 09-27AE		

Set 2 - LH CA515 Steel

1 pcs. A16Q SCLCL 09-18AE	10 pcs.	£270
1 pcs. A20R SCLCL 09-22AE	CCMT 09T304 HQ CA515	
1 pcs. A25S SCLCL 09-27AE		

Set 2 - RH CA6525 Stainless

1 pcs. A16Q SCLCR 09-18AE	10 pcs.	£270
1 pcs. A20R SCLCR 09-22AE	CCMT 09T304 HQ CA6525	
1 pcs. A25S SCLCR 09-27AE		

Set 2 - LH CA6525 Stainless

1 pcs. A16Q SCLCL 09-18AE	10 pcs.	£270
1 pcs. A20R SCLCL 09-22AE	CCMT 09T304 HQ CA6525	
1 pcs. A25S SCLCL 09-27AE		

Double clamp-JCT

Toolholder for turning that discharges coolant in three directions. Improved chip control and longer tool life for a wide variety of workpieces.

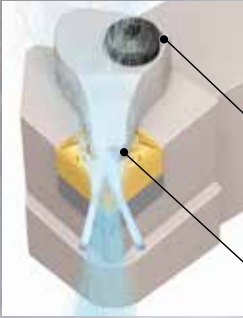

Double-clamp: Firm insert clamp and easy to use in single operations High-density coolant supply close to the cutting edge.

The unique nozzle shape provides coolant in three directions so the cutting edge stays cool.



Featuring latest
HIGH PERFORMANCE
Material specific
Carbide grades

Turning promotion

TURNING KIT OFFERS



Turning Kits

TOOL + 10 INSERTS



Other Turning Kits Available upon request

STEEL KITS

Kit Part No.	Toolholder/ Right	Insert	Kit Part No.	Toolholder/ Left	Insert	KIT PRICE
Steel Kit 1 RH (0.8)	PCLNR2020K12	CNMG 120408 PG CA125P	Steel Kit 1 LH (0.8)	PCLNL2020K12	CNMG 120408 PG CA125P	£72.00
Steel Kit 2 RH (1.2)	DCLNR2020K-12	CNMG 120412 PH CA125P	Steel Kit 2 LH (1.2)	DCLNL2020K-12	CNMG 120412 PH CA125P	£72.00
Steel Kit 3 RH (0.8)	PCLNR2525M-12	CNMG 120408 PG CA125P	Steel Kit 3 LH (0.8)	PCLNL2525M-12	CNMG 120408 PG CA125P	£72.00
Steel Kit 4 RH (1.2)	DCLNR2525M-12	CNMG 120412 PH CA125P	Steel Kit 4 LH (1.2)	DCLNL2525M-12	CNMG 120412 PH CA125P	£72.00
Steel Kit 5 RH (0.8)	DCLNR2020K-12JCT	CNMG 120408 PG CA125P	Steel Kit 5 LH (0.8)	DCLNL2020K-12JCT	CNMG 120408 PG CA125P	£140.00
Steel Kit 6 RH (1.2)	DCLNR2525M-12JCT	CNMG 120412 PH CA125P	Steel Kit 6 LH (1.2)	DCLNL2525M-12JCT	CNMG 120412 PH CA125P	£160.00

STAINLESS STEEL KITS

Kit Part No.	Toolholder/ Right	Insert	Kit Part No.	Toolholder/ Left	Insert	KIT PRICE
Stainless Kit 1 RH (0.8)	PCLNR2020K12	CNMG 120408 MS CA6515	Stainless Kit 1 LH (0.8)	PCLNL2020K12	CNMG 120408 MS CA6515	£72.00
Stainles Kit 2 RH (1.2)	DCLNR2020K-12	CNMG 120412 MS CA6515	Stainles Kit 2 LH (1.2)	DCLNL2020K-12	CNMG 120412 MS CA6515	£72.00
Stainles Kit 3 RH (0.8)	PCLNR2525M-12	CNMG 120408 MS CA6515	Stainles Kit 3 LH (0.8)	PCLNL2525M-12	CNMG 120408 MS CA6515	£72.00
Stainles Kit 4 RH (1.2)	DCLNR2525M-12	CNMG 120412 MS CA6515	Stainles Kit 4 LH (1.2)	DCLNL2525M-12	CNMG 120412 MS CA6515	£72.00
Stainles Kit 5 RH (0.8)	DCLNR2020K-12JCT	CNMG 120408 MS CA6515	Stainles Kit 5 LH (0.8)	DCLNL2020K-12JCT	CNMG 120408 MS CA6515	£140.00
Stainles Kit 6 RH (1.2)	DCLNR2525M-12JCT	CNMG 120412 MS CA6515	Stainles Kit 6 LH (1.2)	DCLNL2525M-12JCT	CNMG 120412 MS CA6515	£160.00

HEAT RESISTANT ALLOYS KITS

Kit Part No.	Toolholder/ Right	Insert	Kit Part No.	Toolholder/ Left	Insert	KIT PRICE
Heat Res. All. Kit 1 RH (0.8)	PCLNR2020K12	CNMG 120408 SG PR115S	Heat Res. All. Kit 1 LH (0.8)	PCLNL2020K12	CNMG 120408 SG PR115S	£72.00
Heat Res. All. Kit 2 RH (1.2)	DCLNR2020K-12	CNMG 120412 SG PR120S	Heat Res. All. Kit 2 LH (1.2)	DCLNL2020K-12	CNMG 120412 SG PR120S	£72.00
Heat Res. All. Kit 3 RH (0.8)	PCLNR2525M-12	CNMG 120408 SG PR115S	Heat Res. All. Kit 3 LH (0.8)	PCLNL2525M-12	CNMG 120408 SG PR115S	£72.00
Heat Res. All. Kit 4 RH (1.2)	DCLNR2525M-12	CNMG 120412 SG PR120S	Heat Res. All. Kit 4 LH (1.2)	DCLNL2525M-12	CNMG 120412 SG PR120S	£72.00
Heat Res. All. Kit 5 RH (0.8)	DCLNR2020K-12JCT	CNMG 120408 SG PR115S	Heat Res. All. Kit 5 LH (0.8)	DCLNL2020K-12JCT	CNMG 120408 SG PR115S	£140.00
Heat Res. All. Kit 6 RH (1.2)	DCLNR2525M-12JCT	CNMG 120412 SG PR120S	Heat Res. All. Kit 6 LH (1.2)	DCLNL2525M-12JCT	CNMG 120412 SG PR120S	£160.00

ALUMINIUM KITS

Kit Part No.	Toolholder/ Right	Insert	Kit Part No.	Toolholder/ Left	Insert	KIT PRICE
Aluminium Kit 1 RH (0.4)	PCLNR2020K12	CNMG 120404 AH KW10	Aluminium Kit 1 LH (0.4)	PCLNL2020K12	CNMG 120404 AH KW10	£76.00
Aluminium Kit 2 RH (0.8)	DCLNR2020K-12	CNMG 120408 AH KW10	Aluminium Kit 2 LH (0.8)	DCLNL2020K-12	CNMG 120408 AH KW10	£76.00
Aluminium Kit 3 RH (0.4)	PCLNR2525M-12	CNMG 120404 AH KW10	Aluminium Kit 3 LH (0.4)	PCLNL2525M-12	CNMG 120404 AH KW10	£76.00
Aluminium Kit 4 RH (0.8)	DCLNR2525M-12	CNMG 120408 AH KW10	Aluminium Kit 4 LH (0.8)	DCLNL2525M-12	CNMG 120408 AH KW10	£76.00
Aluminium Kit 5 RH (0.4)	DCLNR2020K-12JCT	CNMG 120404 AH KW10	Aluminium Kit 5 LH (0.4)	DCLNL2020K-12JCT	CNMG 120404 AH KW10	£140.00
Aluminium Kit 6 RH (0.8)	DCLNR2525M-12JCT	CNMG 120408 AH KW10	Aluminium Kit 6 LH (0.8)	DCLNL2525M-12JCT	CNMG 120408 AH KW10	£160.00

MUCH MORE THAN REGRINDING

RE•NEW

Fast Easy
Reduces your costs
Performance
guarantee
Customisable



OUR RE•NEW CONCEPT

...is easy

Just pack up your tools in their original packaging and ask your local Kyocera Sales Engineer to arrange collection.

...is customisable

Special requirements, measuring protocol etc. are managed through our systems, ensuring that your orders are always processed correctly.

...is fast

Normally you will receive your tools within 2 weeks. Larger quantities of tools, or tools which need special repair, are delivered upon agreement.

...reduces your costs

The regrinding and re-coating process is controlled to "your" specification. Advanced CNC machines, highly trained operators, norm management, databases and integrated routines ensure that your tools will perform better than or equal to a new tool – every time – **with performance guarantee!**

So when you receive your tools from us you will be able to continue working at the same high machining parameters as before.



TO LEARN MORE ABOUT RE•NEW

Visit
www.kyocera-unimerco.co.uk
or call 0114 2788787



Nikken E236+



THE HIGH PERFORMANCE "ENTRY LEVEL" PRESETTER



The New E236+ Tool Presetting machine has been developed as the upgraded entry level option for our new generation of advanced tool presetting machines.

Designed and developed to guarantee a greater accuracy of measurements, improved dimensional stability and excellent reliability the E236+ features a ground natural granite base and column, stainless steel construction and improved ergonomic design. Combined with New firmware and our latest generation 7" TFT LED Touch Screen the system provides full operator control and selection of options and functions via an intuitive icon system allowing operational and functional simplicity that is second to none.

- Spindle System utilises a one piece cartridge - eliminating the need for adaptors and the errors associated with their use.
- New improved and upgraded axis positioning system to allow the framing of the tool profile within the centre of the screen to be made quickly and easily.
- Featuring a natural ground granite base & column, with an upgraded 7" TFT LED Touch Screen.

Spindle System

The E236+ spindle system is fully interchangeable and utilises a one piece precision cartridge - eliminating the need for adaptors and the errors associated with their use.

Software Package

Also included with our E236+ model is our TD236+ software package. Working via your DNC system DPP converts measured tool data into CNC code for direct loading into the machine controller and associated tool offset pages.

TECHNICAL DATA

VERSIONS

- ISO/BT 40, 50 / HSK / VDI "INTERCHANGEABLE" rotating spindle-holder.

TECHNICAL FEATURES

- Measuring range: X axis 130 mm (diameter 260 mm).
- Measuring range: Z axis 360 mm.
- Measuring resolution: X axis 0.001 mm.
- Measuring resolution: Z axis 0.001 mm.
- Electronics driver based on RISC 32 bit processor and integrated vision system.
- C-MOS image sensor framed image area 5mm x 5mm.
- Telecentric lens and LED illuminator.
- Magnifications: 20X.
- TFT colour LCD 7" LED backlight points matrix graphic display (86x150 mm image size).
- Full touch-screen for all presetter operations.
- Intuitive icons and menu-based software.
- Display radius/diameter, mm/inch, abs/incr, analogical/digital.
- Measurement capability by full-screen auto-targeting.
- X axis and Z axis focusing control bars.
- Radius and angle automatic computing cycle.
- 9 numerical machine origin management.
- 9 numerical tool tables management.
- Tool corrector specific storage of T, Lx, Lz, insert radius.
- Data storage on Flash memory.
- USB port for PC connection (Windows OS).
- BIOS update by USB port with TD236+.
- External 24Vcc power supply.
- TD236+ Software – Data Post Processing: correctors file generator, in more than 50 CNC machine-specific formats by the universal post-processors creator. User friendly backup and restore management of machine origins and tool-lists.

OPTIONS

- Label printer.
- ISO / BT / HSK / VDI interchangeable spindle-holders and adaptors.
- Machine Stand.

OVERALL DIMENSIONS

- Length: 570 mm, height: 793 mm, depth: 408 mm, weight: 46 kg.



Kyocera Unimerco production facilities, UK

Kyocera Unimerco Tooling Ltd.

LICHFIELD ADVANCED FACILITIES



Kyocera Unimerco - high end tooling solutions for the metal working industry

Kyocera Unimerco Ltd. manufactures, distributes and services tools for machining, primarily for the metal, woodworking, automotive, aerospace, power generation and Fluid power industries.

Lichfield (Fradley)

The technology centre in Lichfield focuses on effective solutions for production. The tooling concept comprises standard and customized tools, RE•NEW tool maintenance, coating and optimisation guidance.



Manufacturing capability

Capacity consisting of:

- SAACKE CNC grinding centres
- machining centres for PCD tool production (Vollmer, Deckel, Studer, etc.)
- Nano-composite PVD coating plant
- Central systems control
- Air-conditioned production environment
- Autonomous working groups

Capability of manufacturing special tools in:

- Tool design engineers
- Solid carbide
- PCD
- RE•NEW of all tool types incl. PCD



Industrial tooling solutions

Kyocera Unimerco is a global manufacturer and distributor, providing standard and customised cutting tool solutions as well as know-how and optimisation guidance for the manufacturing industry.

The company was founded in 1964 and has since expanded into 17 countries, with more than 700 employees.

Today the company is part of the Japan-based Kyocera Corporation.

In 1998 the Sheffield branch was established. It is specialised in supplying the industrial market with inserts, standard tools and related tooling solutions.



INDUSTRIAL
SUPPLIES LTD

Tel: 0121 274 7140

Your Local Authorised Kyocera Distributor

Edge Industrial Supplies Ltd (Birmingham)

Unit 5, Key Business Park, Kingsbury Rd, Erdington,
Birmingham B24 9PT

Edge Industrial Supplies Ltd (Cradley Heath)

Unit 15, Lodge Forge Trading Estate, Bridge St,
Cradley Heath B64 7RW

Email: [sales@edgeindustrial .co.uk](mailto:sales@edgeindustrial.co.uk)

Contact our sales team for more information